

T5010

S.M.P.T.E. / E.B.U.
TIME CODE
GENERATOR/READER
CHARACTER INSERTER

Operation and Maintenance

Release 1.0
January 24, 1989

Contents

Chapter 1 Introduction	1
1.1 Description	1
1.2 Features	1
1.3 SMPTE and EBU Time Code	2
1.4 Specifications	7
Chapter 2 Installation	9
2.1 Unpacking	9
2.2 Jumper Selectable Options	9
2.3 Connections	10
Chapter 3 Operation	15
3.1 Indicators	15
3.2 Controls	16
Chapter 4 How To	21
4.1 Introduction	21
Chapter 5 Theory Of Operation	23
5.1 Introduction	23
5.2 Generator	24
5.3 Microprocessor	25
5.4 Reader	25
5.5 Video and Character Inserter	26
5.6 Display and Control	27
5.7 Power Supply	27
Chapter 6 Maintenance	29
6.1 Preventive Maintenance	29
6.1.1 Display Brightness	29
6.1.2 Horizontal Position Limit	29
6.1.3 Vertical Position Limit	29
6.1.4 Character Level	29
6.1.5 Video Delay	29
6.1.6 Border Trim	30
6.2 Performance Verification	30
Appendix A Glossary	31

Appendix B Parts List	45
B.1 Resistors	45
B.2 Variable Resistors	48
B.3 Capacitors	48
B.4 Integrated Circuits	50
B.5 Diodes	52
B.6 Transistors	53
B.7 Connectors	53
B.8 Switches	54
B.9 Miscellaneous	54
Appendix C Schematics	57
Index	59

Figures

Figure 1.1: Bi-Phase Mark encoding	3
Figure 1.2: Timing Relationship Between NTSC Video and Time Code	4
Figure 1.3: Timing Relationship Between EBU Video and Time Code	4
Figure 1.4: Longitudinal Time Code Waveform	4
Figure 1.5: SMPTE Vertical Interval Time Code Waveform	5
Figure 1.6: EBU Vertical Interval Time Code Waveform	5
Figure 1.7: Relationship Between Video, Color Frame Identification Pulse and Time Code	6
Figure 2.1: T5010 Back Panel	10
Figure 2.2: T5010 Line Voltage Selector	13
Figure 3.1: T5010 Front Panel	15
Figure 4.1: Typical Installation of the T5010	21

Tables

Table 2.1: 32 BIT PARALLEL INPUT/OUTPUT PIN ASSIGNMENTS	14
Table 3.1: Insert Switch Functions	19

Introduction

1.1 Description

The model T5010 Time Code Generator/Reader/Video Character Inserter generates, reads and displays the 80 bit Society of Motion Picture and Television Engineers (S.M.P.T.E.) and the European Broadcasting Union (E.B.U.) longitudinal time and control code. The model T5010 can also display these codes as either white or black characters in a composite video signal. The model T5010 also provides time or user data from this code at a 34 pin connector on the rear panel.

1.2 Features

This manual applies to main circuit board revision level 2.3 and higher.

The following features are supported by the Telcom Research model T5010 S.M.P.T.E./E.B.U. Time Code Generator/Reader:

- Generates both S.M.P.T.E., E.B.U. and 24 frames/sec. time code
- Jam Sync and Continuous Jam with or without user bits
- Error indicator for Reader time code
- Synchronized indicator for Reader time code
- External Jam Sync control input
- External start/stop control of generator
- High resolution character inserter
- Front panel control of boxed or bordered characters
- Front panel control of reverse character video

- 9 modes of character inserter data display
- Characters position continuously variable
- Optional frames suppression in character inserter
- Color framing
- Direct keyboard entry of time and user bits
- Two isolated time code outputs
- Variable brightness L.E.D. display
- Standard level (+11 dBm.) code output
- Parallel input/output of time or user bits
- Locks to power line if no video/sync
- Rack Mount

1.3 SMPTE and EBU Time Code

Time code is an electronic signal recorded on video tape and is synchronized to the accompanying video signal. The purpose of time code is to uniquely identify each frame of video on a video tape (or other video recording medium). This is done by assigning a number to each frame of video in an HOURS : MINUTES : SECONDS : FRAMES format. This is called the time information (time bits). There are two forms of time code and they both contain the same time and user bit information. They are referred to as longitudinal and vertical interval time codes.

There are also two organizations who set standards which specify the technical details of time code. They are the Society of Motion Picture and Television Engineers (SMPTE) and the European Broadcasting Union (EBU).

Longitudinal time code is a digital signal which uses a code format very similar to that used by computer floppy disks. This signal is recorded on an audio track, cue track or address track of a video tape. Time code uses a Bi-Phase Mark code format that is suitable for recording on magnetic tape. The format is based on transitions between clock pulses. Polarity of the signal, or the direction of the transition is unimportant. Bit positions are separated by clock transitions. If there is no transition between the clock transition for a given bit and the clock transition for the following bit the bit value is a logic 0. If there is a transition between clock transition, the bit value is a logic 1. The format of bi-phase mark encoding is shown in figure 1.1.

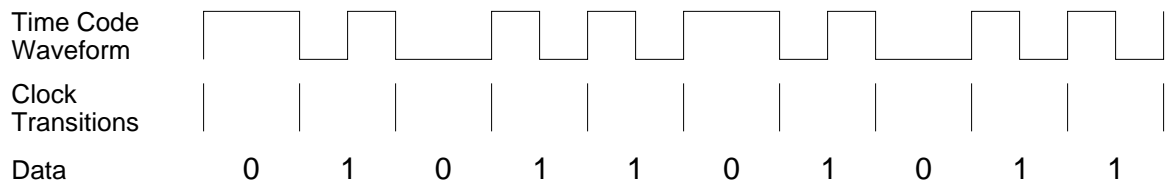

Figure 1.1: Bi-Phase Mark encoding

For each frame of video there is a corresponding frame of time code. Each time code frame consists of 80 bits. These are made up of 16 bits of synchronizing and direction sensing data (the sync word), 26 bits of time information, 32 bits of user information (user bits) and 6 bits of status information. The complete time code frame is repeated once per video frame. The 80 bit positions are divided into 16 four bit groups followed by a 16 bit sync word that identifies the end of one frame and the beginning of the next, as well as the direction of tape movement. 8 of the 16 four bit groups contain the time and status information and are arranged in frame numbers, seconds, minutes and hours order. The code consists of 4 bit time groups alternating with 4 bit groups dedicated to optional user bit information. Time code information is in binary coded decimal form. The *tens of frames* group uses only 2 bits for time (since it need only count up to “2”). The third bit position in this group is used to indicate the Drop Frame (DF) mode. The fourth bit position in this group is used to indicate the proper color lock of the time code generator (color frame flag CF). The *tens of seconds* group uses only 3 bits for time (since it need only count up to 5). The fourth bit position in this group is used to control parity.

Time codes are accurately phase-locked to the video signals with which the codes are to be used. This is necessary to insure that each time code frame is properly timed with respect to the video frame it identifies. This relationship is shown in figure 1.2 for NTSC video and in figure 1.3 for EBU video where the arrow points to the location in the video signal that corresponds to the starting point of the time code frame (the transition between code bit 79 and code bit 0).

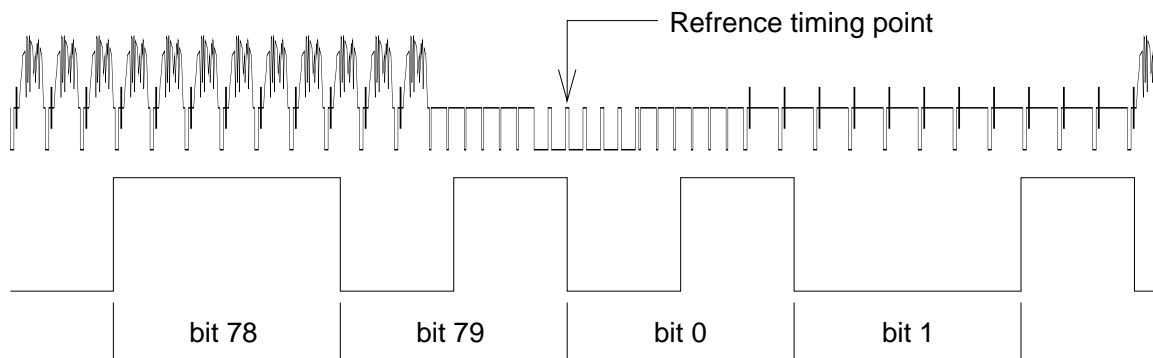

Figure 1.2: Timing Relationship Between NTSC Video and Time Code

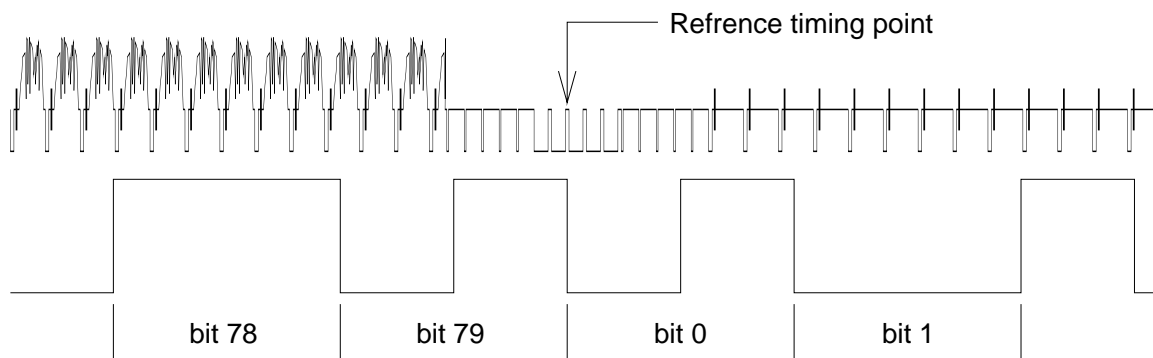

Figure 1.3: Timing Relationship Between EBU Video and Time Code

The format of a full frame of longitudinal time code is shown in figure 1.4. In this figure bit 0 (the start of the frame) is shown on the left and the last bit, bit 79 is shown on the right immediately followed by bit 0 of the next frame. Some of the status bits are labeled with their functions in the SMPTE standard. These bits have different meanings in EBU, except for the color frame flag.

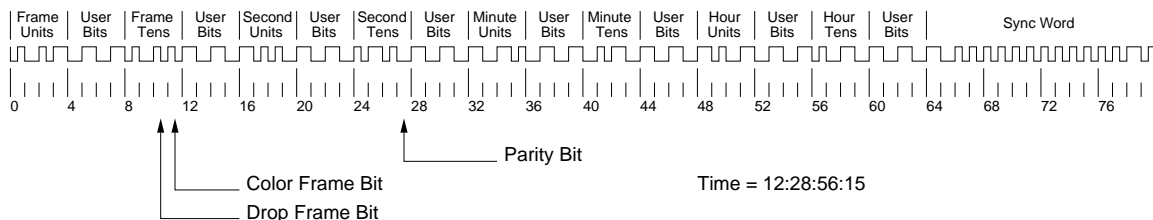

Figure 1.4: Longitudinal Time Code Waveform

SMPTE and EBU longitudinal time codes are very similar. They use the same number of bits per frame and the sync word, the time and the user information are in the same bit positions in both code format standards. The main difference is the number of frames per second in the respective television systems. The SMPTE system has either 29.97 or 30 frames per second and the EBU has a rate of 25 frames per second. This causes the number of bits per second to be 2400 in SMPTE and 2000 in EBU. Also some of the 6 status bits serve slightly different purposes in the two systems.

Vertical interval time code is a digital signal in the form of pulses which are placed on two nonadjacent video lines in the vertical interval of the video signal. Figure 1.5 shows an NTSC video signal with VITC inserted in lines 17 and 19. Figure 1.6 shows an EBU video signal with VITC inserted in lines 19 and 21. There are 90 bits per line in VITC time code. The code is repeated twice in each video field, once on each of two nonadjacent video lines in the vertical interval. Each line contains 18 bits of synchronizing data (the sync bits), 26 bits of time information, 32 bits of user information (user bits), 6 bits of status information and an 8 bit cyclic redundancy check character (CRC). The CRC is the result of doing some arithmetic on the other bits in the code when it is being generated. When the code is recovered this arithmetic is repeated and the result is compared to the recovered CRC and is used to verify that the code is correct and error free. Errors can be caused by noise or dropouts. The CRC provides a 99.61% confidence level in the recovered code.

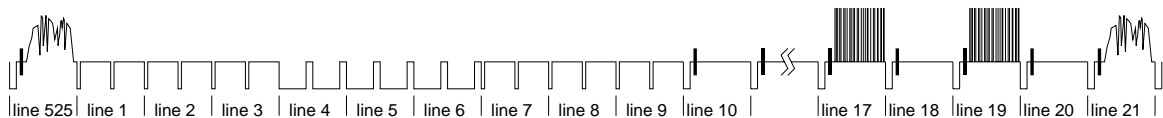

Figure 1.5: SMPTE Vertical Interval Time Code Waveform

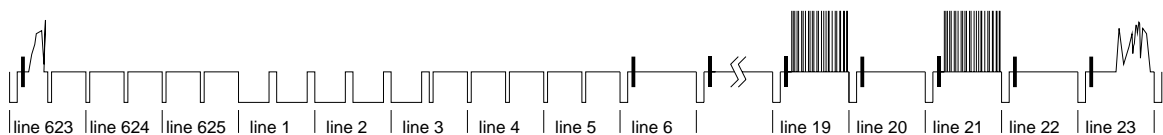

Figure 1.6: EBU Vertical Interval Time Code Waveform

SMPTE Drop Frame (DF) time code was conceived to correct for the NTSC color system frame rate not being exactly 30 frames per second. The NTSC frame rate is only 29.97 Hz, which results in 30 frames being equal to 1.001 seconds. This would produce an accumulative error of about -86.41 seconds per day (the time codes falling behind real time) if no correction was introduced. To fix this problem Drop Frame time code counts 30 frames per second except at the start of each minute not including minutes 0, 10, 20, 30, 40, and 50. At the start of each minute (except as noted above) the first two frames are skipped (or dropped), leaving only 28 frames in the first second of that minute. For instance **15:43:59:29**

will advance to **15:44:00:02**. Time code frames numbered **15:44:00:00** and **15:44:00:01** do not exist in Drop Frame mode. This scheme keeps the time codes in step with real time when used with the NTSC color system. Utilizing the DF mode results in a static error of only +75 milliseconds per day, \pm any inherent sub-carrier error. EBU time code has no equivalent of Drop Frame because the frame rate in that color system divides the second into 25 parts with no remainder.

Color Framing is a result of the growing sophistication of video tape editing. In color television not all frames are the same, even if there is no change in the picture content. The color part of the signal changes from frame to frame. In NTSC there are two variants of a frame and in EBU there are 4. These may be thought of as a repeating sequence of 'A B A B A B' in NTSC or 'A B C D A B C D' in EBU. The result of these minor differences between frames is that if the sequence is not preserved across edits, a horizontal shift in the picture occurs at the edit point. This is only visible if the picture content is substantially the same on either side of the edit. In most situations this shift is unnoticeable. In order to avoid disturbing the sequence the NTSC system assigns even frame numbers to 'A' frames (fields 1 and 2) and odd numbers to 'B' frames (fields 3 and 4). Therefore to maintain the sequence, if the frame on one side of the edit is odd make sure that the frame on the other side is even.

Modern sync generators provide a color frame identification pulse which identifies field one of the 4 field (NTSC) or 8 field (EBU) video signal. This is shown for the NTSC system in figure 1.7 on page 6. The video signal is shown as the top waveform, the color frame identification pulse is shown as the middle waveform and time code is shown as the bottom waveform. The color frame identification pulse is shown as occurring at line 10 of field 1.

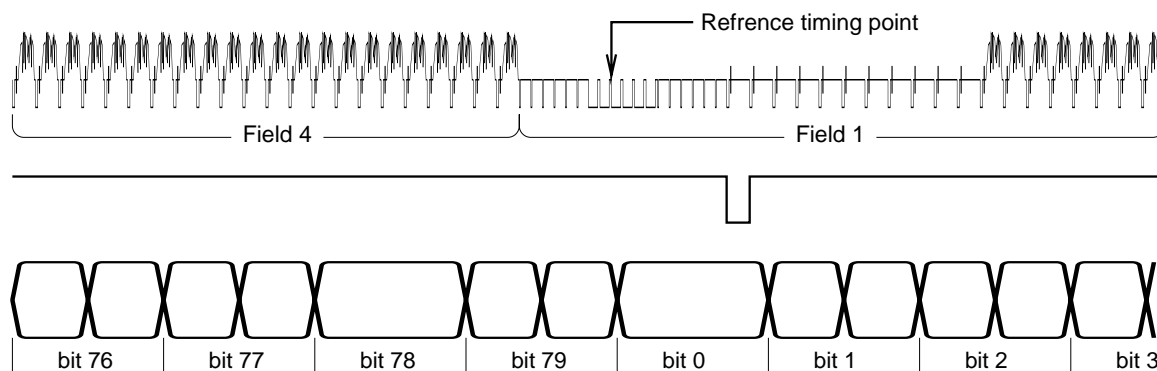

Figure 1.7: Relationship Between Video, Color Frame Identification Pulse and Time Code

In EBU the problem is a little more complicated because the sequence is 4 frames (an even number) and the time code is based on 25 frames per second (an odd number). Color framing is achieved by assigning time code numbers to the video frames in a sequence that guaranties that the remainder when dividing the sum of the frames count and the seconds count by 4 ((frames + seconds) / 4) is 0 for a 'D' frame (fields 7 and 8), 1 for a 'A' frame (fields 1 and 2), 2 for a 'B' frame (fields 3 and 4) and 3 for a 'C' frame (fields 5 and 6).

1.4 Specifications

- Time Code Outputs** Two isolated pseudo balanced outputs on 3 pin male XLR type connectors. These may be treated as 4 unbalanced outputs. See section 2.3 on page 10 for details. S.M.P.T.E. or E.B.U. time code at +11 dBm, 50% duty cycle, balanced line 600 ohms impedance, 25 microsecond rise time.
- Reference Sync Input** Composite sync or video loop through at 0.5 to 4 volt peak to peak level. This is the master timing reference for the time code generator. It must conform to E.I.A. RS170 or C.C.I.R. Report 624-1.
- Video Input** Composite sync or video (loop through) at 1 volt peak to peak nominal level. It should be synchronous with the reference sync input for a stable character display. If it is not, microprocessor timing conflicts may result in some video fields not having characters properly inserted.
- Video Outputs (2)** These outputs have unity gain from the character inserter input and are 75 ohms source terminated. The white level of characters or border is internally adjustable from 0 to 140 units.
- Color Framing Input** Negative edge triggered input. Level 2 to 8 volts, A.C. coupled. 15 Hz. for NTSC, 6.25 HZ. for PAL. This pulse must occur after the sixth wide pulse in the vertical interval preceding field 1 and before the sixth wide pulse in the vertical interval preceding field 3 of the 4 (8 PAL) field color sequence. That is during fields 1 or 2 of the 4 (8 PAL) field color sequence.
- External Jam Input** Negative edge triggered TTL logic level input, internal pull-up, 1 ma. current source. This input is recognized at the start of the next frame.

Time Code Input	S.M.P.T.E./E.B.U. time code between -25 and +25 dBm, 50% duty cycle $\pm 15\%$, balanced line 20,000 ohms input.
Parallel Input/Output	TTL positive logic level, 32 bits.
Power	90 to 130 or 200 to 250 volts A.C. at 45 to 70 Hz., 20 VA.
Size	3.5 in. high, 19 in wide, 12 in. deep.
Weight	6.50 kg., 15 lbs.
Environmental	0°C to +60°C (32°F to +140°F) operating, -20°C to +85°C (8°F to +185°F) storage, 0 to 85% relative humidity (no condensation).

Installation

2.1 Unpacking

The T5010 time code generator/reader is shipped, with accessories, in a single carton. After opening the carton, carefully examine the equipment for damage that may have occurred during shipment, and report any damage to the carrier and Telcom Research.

2.2 Jumper Selectable Options

There are 4 shorting plug positions located on the right hand edge of the main circuit board, as viewed from the front of the unit. They function as follows:

Time/User	When this jumper is installed, the parallel interface will be used with the time code user bits information (it will be an input or an output based on the In/Out jumper described below). When the jumper is omitted, the parallel interface will be used with the time code time information.
In/Out	When the jumper is installed, the parallel interface will be used as an input to the T5010 generator/reader. When the jumper is omitted, the parallel interface will be used as an output from the generator. See the footnote on page 10.
Test	Installing this jumper requires that the start of the incoming time code frame is synchronous (within ± 4 time code bits) with respect to the point in the video signal vertical interval defined as the start of the frame by the S.M.P.T.E. or the E.B.U. when in continuous jam. This timing relationship is shown for S.M.P.T.E. in figure 1.2 on page 4 and for E.B.U. in figure 1.3 on page 4. When the jumper is removed this requirement is

waived. This may be desirable with some helical formats (U-matic, SVHS, etc.) because the tracking control shifts the phase of the time code or audio track by a large amount with respect to the video signal, especially on interchanged tapes. For asynchronous time code (time code drifting relative to the video signal) continuous jam is NOT recommended. If continuous jam is used with asynchronous time code frames will be skipped or duplicated. If you have asynchronous time code that must be copied use normal (momentary) jam. Jam User

When installed, this jumper¹ will cause the user bits to be included in all Jam Sync operations. When omitted, the user bits will not be affected by Jam Sync operations.

2.3 Connections

All signal connections to and from the T5010 time code generator/reader are made by industry standard BNC and XLR connector at the back of the generator/reader as shown in figure 2.1.

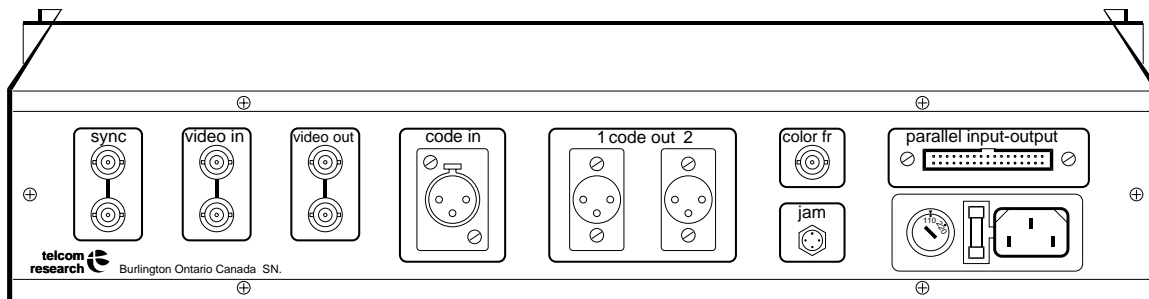

Figure 2.1: T5010 Back Panel

Time Code Outputs

Each of the two time code outputs will drive a balanced 600 ohm line, providing a nominal level of +11 dBm. Each output also may be used as 2 unbalanced outputs, in which case they should be terminated with a 300 ohm resistor to ground. It is not necessary to terminate unused output pins. The required mating connectors are Switchcraft A3F or equivalent. Pin 1 is ground and the signal is on pins 2 and 3.

1. Installing IN/OUT and JAM USER simultaneously selects an ambiguous set of options. The user bits will be programmed to come from both the parallel input and jam operations. Under these circumstances the T5010 will ignore the JAM USER jumper.

- Reference Sync Input** This input requires video or sync and is used as the main reference for the time code generator. The level of this signal is not critical and may vary from .5 to 5 volts peak to peak, but the sync portion of the signal must conform to E.I.A. RS170 or C.C.I.R. Report 624-1 broadcast specifications during the vertical interval. The sync input is a high impedance loop through input using BNC connectors. Connect the video or sync signal to the upper BNC connector. If this is the end of the video or sync line, place a 75 ohm termination on the lower BNC connector, otherwise, continue the video or sync line from the lower BNC connector. Be sure that this line is terminated at it's final destination.
- Time Code Input** The T5010 time code generator/reader/character inserter will accept balanced or single ended S.M.P.T.E. or E.B.U. time code. For balanced input operation, connect the shield (ground) to pin 1 of the XLR input connector and the signal leads to pins 2 and 3. For unbalanced input operation, connect the shield (ground) to pins 1 and 2 of the XLR input connector and the signal lead to pin 3.
- This is a bridging (high impedance) input and if used in a 600 ohm system a terminating resistor should be installed at the end of the time code line in order to maintain correct levels in the system.
- Video Input** This is a loop through connection. Connect the video signal to the upper BNC connector. If this is the end of the video line, place a 75 ohm termination on the lower video in BNC connector, otherwise, continue the video line from the lower video input BNC connector. Be sure that this line is terminated at it's final destination.
- Video Output** The 2 video outputs are source terminated 75 ohm outputs which are isolated from each other. They provide unity gain from the video input point. It is not necessary to terminate an unused video output.
- Color Frame Input** This input requires a 2 to 8 volt signal with a low going edge which indicates the start of the E.I.A. 4 or P.A.L. 8 field sequence (fields 1 & 2). The negative edge must occur after the 6 (5 for E.B.U.) wide pulses in the vertical interval at the start of field 1 and before the 6 (5 for E.B.U.) wide pulses in the vertical interval at the start of field 3 for proper operation. This signal is A.C. coupled

internally and may be positive or negative with respect to ground. If this signal is not available then leave this input unconnected. See page 6 for further details about color framing.

External Jam Input This is a negative edge triggered TTL logic level input, internal pull-up, 1 ma. current source. When the negative edge is detected, a Jam Sync operation is initiated. It may be used with a simple remote push button (it is debounced) or it may be connected to the record logic in a VTR. If the front panel Error indicator is on then the jam operation is deferred until the error clears. This input is recognized at the start of the next frame. This is pin B of the 4 pin CONTROL connector and the return (ground) is pin A.

External Hold Input This input is used to place the generator in the hold mode. It is a level controlled TTL type input with an internal 4.7k pull-up to 5 volts which produces a 1 ma. current source. When pulled low, the generator time will stop advancing, the generator will resume counting when this line is released. This is pin C of the 4 pin CONTROL connector and the return (ground) is pin D.

Control Connector	Pin A	External Jam common
	Pin B	External Jam input
	Pin C	External Hold input
	Pin D	External Hold common

Parallel Input/Output Parallel access to the time and user bits (as selected by the jumper plug located on the main P.C. board) is provided at TTL levels. This is a 34 pin 'ribbon cable' type connector. Refer to table 2.1 on page 14 for the pin assignments for this connector. Also see to section 2.2 on page 9 for information on jumper settings.

Line Voltage Selection The model T5010 time code generator/reader/character inserter may be set to operate in 2 line voltage ranges as shown in figure 2.2. The left side of figure 2.2 shows the setting for the 110 volt range and the right side shows the 220 volt range setting.

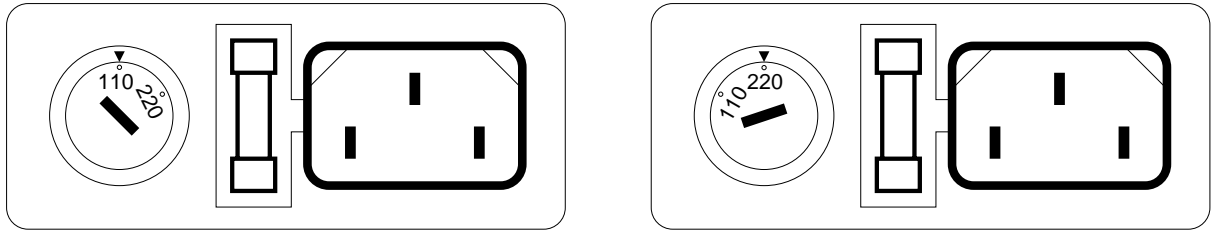

Figure 2.2: T5010 Line Voltage Selector

Pin	Time Function		User Function	
1	common			
2	common			
3	frames bit 0	LTC bit 0	user bit 0	LTC bit 4
4	frames bit 1	LTC bit 1	user bit 1	LTC bit 5
5	frames bit 2	LTC bit 2	user bit 2	LTC bit 6
6	frames bit 3	LTC bit 3	user bit 3	LTC bit 7
7	frames bit 4	LTC bit 8	user bit 4	LTC bit 12
8	frames bit 5	LTC bit 9	user bit 5	LTC bit 13
9	drop-frame flag	LTC bit 10	user bit 6	LTC bit 14
10	color-frame flag	LTC bit 11	user bit 7	LTC bit 15
11	seconds bit 0	LTC bit 16	user bit 8	LTC bit 20
12	seconds bit 1	LTC bit 17	user bit 9	LTC bit 21
13	seconds bit 2	LTC bit 18	user bit 10	LTC bit 22
14	seconds bit 3	LTC bit 19	user bit 11	LTC bit 23
15	seconds bit 4	LTC bit 24	user bit 12	LTC bit 28
16	seconds bit 5	LTC bit 25	user bit 13	LTC bit 29
17	seconds bit 6	LTC bit 26	user bit 14	LTC bit 30
18	parity bit	LTC bit 27	user bit 15	LTC bit 31
19	minutes bit 0	LTC bit 32	user bit 16	LTC bit 36
20	minutes bit 1	LTC bit 33	user bit 17	LTC bit 37
21	minutes bit 2	LTC bit 34	user bit 18	LTC bit 38
22	minutes bit 3	LTC bit 35	user bit 19	LTC bit 39
23	minutes bit 4	LTC bit 40	user bit 20	LTC bit 44
24	minutes bit 5	LTC bit 41	user bit 21	LTC bit 45
25	minutes bit 6	LTC bit 42	user bit 22	LTC bit 46
26	unassigned	LTC bit 43	user bit 23	LTC bit 47
27	hours bit 0	LTC bit 48	user bit 24	LTC bit 52
28	hours bit 1	LTC bit 49	user bit 25	LTC bit 53
29	hours bit 2	LTC bit 50	user bit 26	LTC bit 54
30	hours bit 3	LTC bit 51	user bit 27	LTC bit 55
31	hours bit 4	LTC bit 56	user bit 28	LTC bit 60
32	hours bit 5	LTC bit 57	user bit 29	LTC bit 61
33	unassigned	LTC bit 58	user bit 30	LTC bit 62
34	unassigned	LTC bit 59	user bit 31	LTC bit 63

Table 2.1: 32 BIT PARALLEL INPUT/OUTPUT PIN ASSIGNMENTS

Operation

The operation of the T5010 time code generator/reader/character inserter is very straight forward. This section describes the function of all the controls and indicators on the front panel of the T5010 time code generator/reader/character inserter.

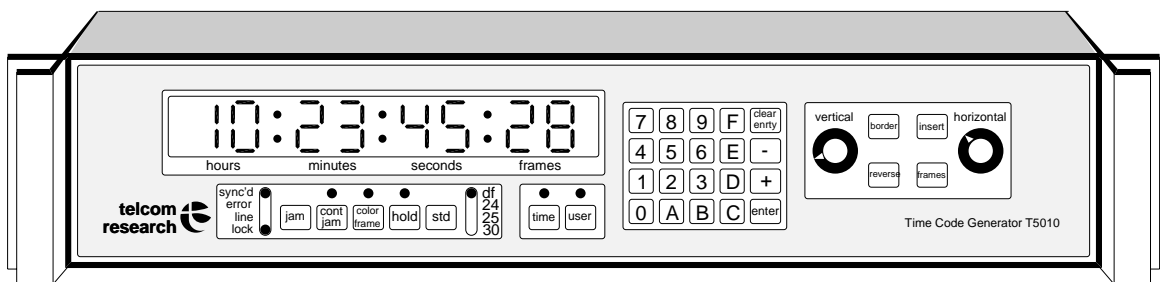

Figure 3.1: T5010 Front Panel

3.1 Indicators

8 Digit L.E.D. Display Indicates the time in hours, minutes, seconds and frames or the 8 groups of user bits in their 4 bit hexadecimal representation.

Sync'd Indicates that the received time code for a jam operation has a sync word which is within ± 4 bit times of the generator's sync word. See the discussion of asynchronous time code under the Test heading in section 2.2 on page 10 for the significance of the SYNC'D indicator.

Error Indicates that a sync word did not occur when expected in the time code being received by the Jam Sync reader.

Line	Indicates that the reference sync or video signal is missing or defective, and the generator has reverted to power line lock.
Lock	Indicates that the phase locked loop for the transmit clock rate was able to lock to the supplied reference, if this light is off, the supplied reference signal should be checked.
Continuous Jam	Flashes to indicate that the generator time will be loaded from the reader time if the Error indicator is not illuminated and the SYNC'D indicator is illuminated. See the discussion of asynchronous time code under the Test heading in section 2.2 on page 10 for the significance of the SYNC'D indicator.
Framed	Indicates that the generator is producing time code which has a number sequence which has the proper relationship to the 4 field (N.T.S.C.) or 8 field (E.B.U.) standard. This indicator is inoperative in the 24 and 30 frame modes.
DF, 24, 25, 30	The standard to which code is being generated is indicated by one of these four lights.
Hold	Indicates when lighted that the generator is stopped. Code is still being generated but the time is not being updated.
Time	Indicates that the LED display is showing the contents of the time register.
User	Indicates that the LED display is showing the contents of the user register.

3.2 Controls

Jam	Sets the generator to the value of the received time code if the Error indicator is extinguished. If the Error indicator is on then the jam operation is deferred until the error clears. An external jam connection is available on the back panel of the T5010. Refer to page 12 for details.
------------	---

Continuous Jam	At the start of every frame, the generator will be set to the value of the received time code if the Error indicator is extinguished and the SYNC'D indicator is illuminated. All internal decoding delays are compensated. The time information in the frame currently being generated is identical to the time information in the frame currently being read if the received time code numbering sequence is ascending. See the discussion of synchronous time code under the Test heading in section 2.2 on page 10 for the significance of the SYNC'D indicator.
Color Frame	Forces the generator to synchronize to the external color framing signal. Has no effect if no color framing signal is present or the generator is in the 24 or 30 frame mode. See page 6 for more information on color framing.
Hold	Stops the generator time count from advancing. The generator outputs repeat the same time code frame. Pressing the key again causes the generator to resume counting. An external hold connection is available on the back panel of the T5010. Refer to page 12 for details.
Standards	The T5010 time code generator/reader can be set up to provide any of the following standards E.I.A., DF (drop frame), E.B.U., or 24 frames per second. The switch on the front of the unit will select the required standard.
Time	Causes the T5010 generator/reader/character inserter to display the TIME DATA of the time code on the front panel L.E.D. readout.
User	Causes the T5010 generator/reader/character inserter to display the USER DATA of the time code on the front panel L.E.D. readout. If pressed twice in one second, the incoming time code time information will be the source of the generator user bits. This mode may be terminated by first pressing USER an then ENTER. 0-9 Enters the value of the key into the keyboard register for subsequent use by the ENTER, + or – keys. These keys operate in both the TIME and USER display modes.
A-F	Enters the value of the key into the keyboard register for subsequent use by the ENTER, + or – keys. These keys operate only if the USER display is selected.

CE	Clears the keyboard register to 00:00:00:00.
+	Adds the contents of the keyboard register to the generator user or time register.
-	Subtracts the contents of the keyboard register from the generator user or time register.
Enter	Transfers the contents of the keyboard register to the generator user or time register. If the incoming time code time information is the source of the generator user bits, this mode will be terminated by pressing ENTER whenever the USER indicator is on. See section 3.2.0 above.
	Border Alternates between video characters with a border and video characters contained within a rectangular cutout in the picture.
Inverse	Reverses the video levels of the characters and the border (cutout). White characters black border become black characters with white border.
Frames	Alternate action control which suppresses or enables the display of frames by the video character inserter.
Insert	This key steps the character inserter through 9 modes of video information display as shown in table 3.1 on page 19.
Horizontal	This control positions the inserted characters horizontally in the video display.
Vertical	This control positions the inserted characters vertically in the video display.

1. READER TIME GENERATOR TIME
 READER USER GENERATOR USER
2. READER TIME
3. GENERATOR TIME
4. READER USER
5. GENERATOR USER
6. READER TIME GENERATOR TIME
7. GENERATOR TIME
 GENERATOR USER
8. READER TIME
 READER USER
9. NO DISPLAY

Table 3.1: Insert Switch Functions

How To

4.1 Introduction

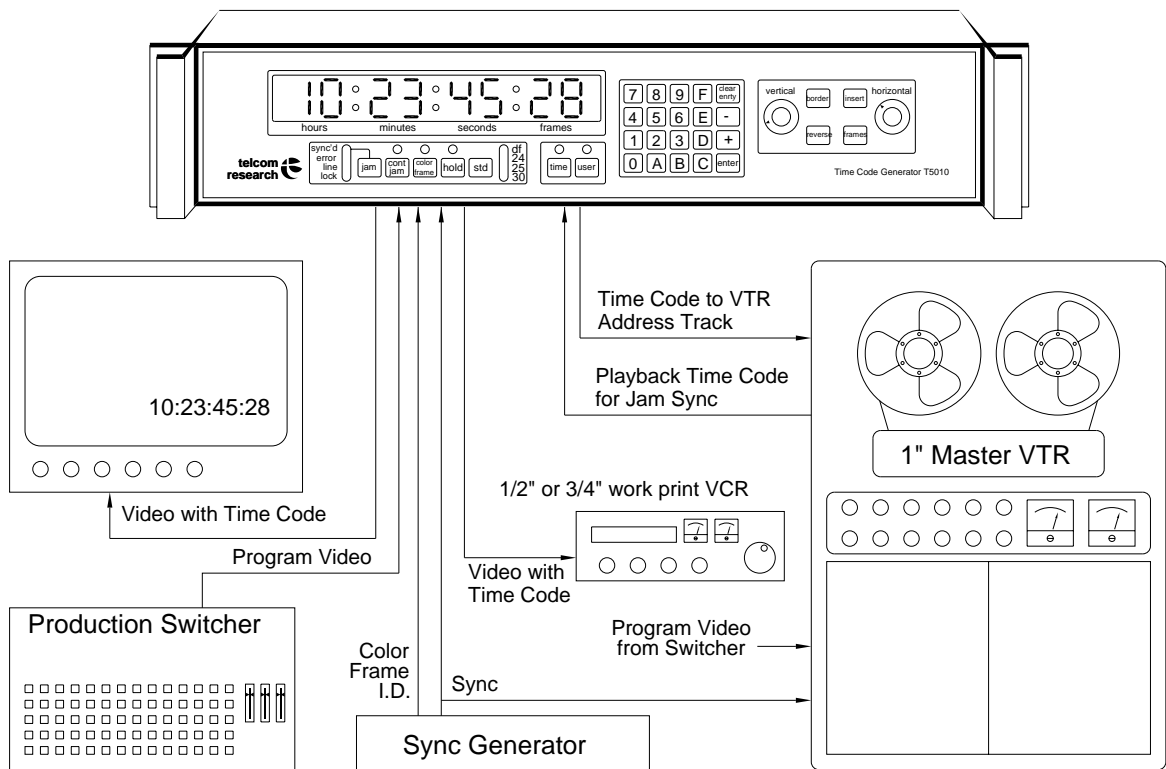

Figure 4.1: Typical Installation of the T5010

Theory Of Operation

5.1 Introduction

Schematics for the T5010 time code generator/reader/character inserter may be found in the last section of this manual.

The heart of the T5010 time code generator/reader/character inserter is a Zilog Z80A microprocessor. Extensive use has been made of large scale intelligent microprocessor support devices.

Two levels of interrupt are used in the T5010 Jam Sync time code generator/reader/character inserter. One is a non-maskable and the other is maskable and may be enabled and disabled under software control. The purpose of an interrupt is to provide service to an external device, usually an input or output device, immediately on demand. An alternate method would be for the main program to examine the status of all devices external to the microprocessor to see if they require service. Both schemes are used in the T5010 time code generator/reader.

The interrupt circuit will interrupt the main program execution of the T5010 time code generator/reader and force the microcomputer to execute a specific service program and then return to the main program at the point at which it was interrupted. The service program saves all the registers of the microprocessor and then services the device which caused the interrupt. When the device service has been completed, the service program then restores all of the microprocessor registers and returns control to the program which was interrupted.

The maskable interrupt is used for the generator because it cannot tolerate timing uncertainty when it needs service.

The time code generator requires very predictable response timing when it requests the time code data from the microprocessor. This is because most of the counters in the generator phase locked loop are implemented in software. Any timing variations in these counters will show up as jitter in the time code output.

The non-maskable interrupt is used to recover from a microprocessor error. The main section of the program triggers a retriggerable one-shot U-19. If this one-shot ever times out, a non-maskable interrupt is generated. This causes the integrity of the data memory to be checked. If data memory passes certain tests, then the peripheral devices are reprogrammed and control is passed to the main section of the program. If the tests fail then a master reset is initiated.

5.2 Generator

See Drawing T8205. The time code generator consists of a sync separator, a reference frame pulse detector, a serial output port, a phase-locked loop oscillator and phase detector and an integrating line driver. All other functions, including the bi-phase encoding and phase locked loop frequency divider, are handled by the microprocessor software.

Reference sync or video enters the main board and is clamped at the tip of sync by D-301 and converted to a logic level by comparator U-301. Dual one-shot U-303 ignores equalizing pulses and generates a 10 microsecond pulse coincident with the leading edge of horizontal sync when enabled by vertical one shot U-302.

Separated sync is also fed to vertical integrator Q-301, which triggers one-shot U-302 to produce a 10 microsecond pulse during the vertical interval. This output enables U-303 which will produce a reference frame pulse only during the vertical interval where horizontal and vertical sync are coincident.

This reference frame pulse drives the comparator reference input of the phase-locked loop U-307.

The oscillator output of the phase locked loop is a square wave at 160 time frame rate. This is used to clock data out of serial port U-12. This data comes from the micro computer already encoded in bi-phase format. When U-12 requires data, it interrupts the microprocessor, which then loads the next 8 time code bits into U-12. The micro computer does all the data formatting and time keeping for the code and also inserts the sync word. At 80 bit intervals, the program pulses serial port U-12, pin 24 which is connected to the phase-locked loop variable input (U-307 pin 3). This closes the loop and insures that the code frame starts during the vertical interval at the start of the video frame when the loop is in a locked condition. This occurs during the vertical interval which is NOT the start of the time code frame.

Data out of U-12 pin 19 is in Manchester-II bi-phase format. U-23, Q-302, Q-303, Q-304, Q-305, R-320, R-321, C-314, and C-315 form an integrating line driver with a rise time of 25 microseconds. This drives the output lines through source termination resistors R-324, to R-328.

5.3 Microprocessor

See Drawing T8200. The Z80A microprocessor (U-3) controls all operations of the T5010 time code generator/reader/character inserter. The control program is stored in U-8 with U-9 provided for future expansion. Data is stored in RAM chips U-10 and U-11. Memory devices are selected for bus transactions by U-5 and I/O devices by U-6. The 4 Mhz. system clock signal is generated by crystal oscillator U-1, and it is used by U-2, U-3, U-12, U-13 as well as U-14

5.4 Reader

See Drawing T8201. The time code entering through the XLR connector is A.C. coupled to input pins 2 and 3 of comparator U-40, which restores the code to a rectangular waveform by slicing at the zero crossings. A slight amount of positive feedback is provided by R-82 and C-41 to insure clean switching. This circuit will typically recover code down to a level of 10 mv. r.m.s. and has an upper limit above 20 volts r.m.s.

Incoming time code data appears at U-39 pin 8 and is also clocked through U-38 pin 5 into U-39 pin 9. At U-39 pin 10, the code is converted to a pulse train of constant frequency (time code clock frequency) with "zero" bit cells having a duty cycle of 50% and "one" bit cells having a duty cycle less than 50% (pulse width coding). U-39 pin 11 produces a positive pulse for every transition at its input, effectively doubling the frequency of the data and converting it to pulse position coding. The phase locked loop U-37 locks to this frequency (2 times time code clock frequency). When a zero bit cell is received a low output is produced at U-37 pin 1 at the midpoint of the zero bit cell time which is then clocked by the output of U-37 pin 4 into U-38 pin 9 where it appears as inverted data at U-38 pin 12. This data is then inverted and level shifted at U-23 pin 4 and clocked by the output of U-23 pin 6 into pin 3 of U-12. This is a programmable communication interface operating in the synchronous mode. The data at U-38 pin 12 is also fed back to U-38 pin 3 to clock original data through U-38.

The received data in U-12 is then examined bit by bit to find a 16 bit sync word. Time code data is then accumulated and transferred to memory by the microprocessor. If the data passes several error checks then it is made available to the generator for Jam Sync and Continuous jam operations. If a jumper is installed on the main circuit board in the unlabeled position next to the time/user jumper and then the TIME or USER button on the front panel is pressed, the reader time or user data will be displayed on the L.E.D. readouts and in the video if video display is enabled. This may be useful in trouble shooting the reader circuit.

5.5 Video and Character Inserter

See Drawing T8202. The character inserter is built around an Intel 8276 CRT programmable controller U-16. This device is not normally used with an external video signal, however by gating the character clock it can be made synchronous.

External video enters the T5010 main board at P5 pin 2 where it is A.C. coupled to emitter follower Q-18. The output of Q-18 is A.C. coupled to sync tip clamp diode D-2, sync separator U-42 and CMOS analog switch U-34. U-42 drives vertical integrator Q-17 and horizontal equalizing pulse remover U-19. Horizontal and vertical drive are then used by position monostable U-18.

U-15 is programmed to have a shorter line length and fewer lines per field than the external video signal. When U-15 reaches the end of a line or field it's drive output (VRTC or HRTC) clocks one half of flip-flop U-20. This stops the video dot clock which in turn stops U-15. The dot clock is restarted by U-18 from external sync and the settings of vertical and horizontal position controls RV-201 and RV-202.

U-15 provides 7 character code outputs (CC0 to CC6) and 4 line count outputs (LC0 to LC3). These form the address lines for foreground PROM U-30 and background PROM U-31. The background PROM is used to cut a 'hole' in the external video signal which is slightly larger than the character to be inserted while U-30 provides the actual character. This leaves a border around the character. If U-31 is disabled by U-15 then a rectangular box is cut out of the video.

U-15 pin 36 (RVV) is used to invert the character and border levels, pin 32 (HLGT) is used to select border or box mode and pin 33 (GPA0) inhibits the display of characters in the video. Frames suppression is done by reprogramming the number of characters per line in U-15.

Character border width is set by RV-4 which stretches the switching signal to CMOS analog switch U-32, which switches between the external video and the character video. Character positioning within the cutout is adjusted by selecting a tap on digital delay line U-32. There are 6 jumper plug positions at a header labeled VIDEO DELAY. Position '0' is direct with no delay and positions '1' through '4' produce 1 to 4 dot clock periods of delay. The position marked 1/2 trims this delay by 1/2 a dot clock cycle. If position '0' is selected then no other jumper should be installed. Only one jumper should be installed at positions '1' to '4' with or without a jumper at position 1/2.

The output of U-34 is connected to video amplifier U-41. This provides a gain of 2 and sufficient power to drive two 75 ohm lines.

5.6 Display and Control

See Drawing T8203. The 8 digit L.E.D. display is multiplexed by U-14, a programmable keyboard/display interface circuit. This device also scans the 30 control keys on the front panel. The multiplex count (SL0 – SL2 of U-14) is decoded by U-7 whose outputs are connected to the digit drivers Q-1 through Q-8 whose outputs in turn are connected to the digit L.E.D. anodes as well as to the 10 L.E.D. status indicators. Transistors Q-10 through Q-16 drive the 7 cathode segments and Q-9 drives the status L.E.D. cathodes. Monostable multivibrator U-46 is triggered at the start of each digit interval and enables decoder U-7. Brightness of the display is controlled by adjusting RV-5 which controls the period of U-46.

5.7 Power Supply

See Drawing T8204. The T5010 time code generator/reader/character inserter is powered by a universal transformer. The model T5010 may be set to operate in 2 line voltage ranges as shown in figure 2.2 on page 13. The left side of figure 2.2 shows the setting for the 110 volt range and the right side shows the 220 volt range setting. Selection of the correct primary winding configuration for a given line voltage is made by setting the switch on the fuse holder/EMI filter assembly as shown in figure 2.2.

Three regulated voltages are provided, positive 5 volts, positive 12 volts and negative 5 volts. The positive 5 and negative 5 volts supplies are derived from a center tapped full-wave bridge circuit, D-8 through D-11, C-58 and C-59. The positive 5 supply is regulated by U-45 which is mounted on the rear panel for heat sinking. This provides the L.E.D. display, power for logic devices and the microprocessor and it's memory and peripheral devices. The negative 5 volt supply is regulated by U-43 which requires no heat sinking. This supply is used by the reader input circuit, the video sync separator and the video amplifier circuit. The positive 12 volt supply is derived from a voltage doubler consisting of D-4 to D-7 and C-55 to C-58 and is regulated by U-44 which also requires no heat sinking. This supply is used by the reader clock and data separator and the video amplifier circuit.

Maintenance

6.1 Preventive Maintenance

Under normal use, preventive maintenance is not required. There are however, 6 adjustments inside the T5010 which may be adjusted by the user.

6.1.1 Display Brightness

RV-5 sets the brightness of all L.E.D. display devices on the front panel of the T5010.

6.1.2 Horizontal Position Limit

Turn the front panel Horizontal Position control (RV-202) fully clockwise. Adjust Horizontal Trim (RV-2) to the point just before character height doubles.

6.1.3 Vertical Position Limit

Turn the front panel Vertical Position control (RV-201) fully counterclockwise. Adjust Vertical Trim (RV-1) to the point just before character video appears on one field only (display flickers).

6.1.4 Character Level

Observe the video output on a waveform monitor and a video monitor. Adjust RV-3 (Character Level) as required.

6.1.5 Video Delay

Install a jumper plug at position '0' on the Video Delay Header. Check that the character is centered within the border. If it is not, remove the jumper at '0' and install it at position '1' to '4' until the best centering is obtained. Install a second jumper at position '1/2' if required. This may make it necessary to move the original jumper 1 position.

6.1.6 Border Trim

Adjust RV-4 labeled Border Trim for a symmetrical border. If this adjustment is made, it may be necessary to repeat the Video Delay jumper selection.

6.2 Performance Verification

Connect a video or sync signal to connector labeled REF SYNC with a BNC connector and terminate the other end of the loop through with a 75 ohm termination. With an oscilloscope, observe the pulse at pin 1 of U-6. This is a positive 5 volt level with a narrow pulse going to ground. (Note – This is the phase error in the phase locked loop.) The width of this pulse should average 5 microseconds, but will not be constant. This pulse should be at a 30 Hz rate. Disconnect the REF SYNC signal and observe that this pulse becomes very wide. Reconnecting REF SYNC should cause this signal to revert to about 5 microseconds. The magnitude of this pulse is proportional to the phase difference between the time code output and the vertical component of the REF SYNC signal.

Observe the time code output signals and confirm that the rise time of each phase is 20 microseconds \pm 5 microseconds. The level should be about 4 volts peak to peak on each phase.

Connect the time code output to a time code reader and alternately press the Hold button this should alternately stop and start the code displayed by the reader and the Hold led should light when the code is stopped.

If unsatisfactory results are obtained during any of the above procedures, refer to the Theory of Operation section for guidance in more detailed trouble shooting.

Glossary

ASCII	American Standard Code for Information Interchange; a standardized, eight bit data character encoding system used internationally to code alphabetic, numeric, and other symbols into binary values for interchange between computers.
Assemble Editing	Editing new material to the end of previously recorded material. This requires a jam sync time code generator. Assemble editing is done on fully erased tape. Also see insert editing.
Asynchronous	In data communications, transmission in which the time interval between data characters may be of unequal length. Transmission is controlled by start and stop bits at the beginning and end of each character. See also SYNCHRONOUS.
Auto Assembly	See Auto Conforming.
Auto Conforming	Automatic editing of videotape to conform to previously generated edit decision list.
B.C.D.	Binary Coded Decimal. A method of representing the digits 0 through 9 using four bits.
Back Porch	The part of a composite signal that follows the horizontal sync pulse and extends to the trailing edge of the corresponding blanking pulse.
Back Time	To calculate an in-point by selecting the outpoint and subtracting the duration, i.e. the length of the edit.
Bi-Phase Mark	An encoding method used by SMPTE and EBU time codes to combine the clock and the data in the same signal.

Bit	In the binary notation either of the characters 0 or 1. The smallest logical element.
Black Level	The level of the television picture signal corresponding to the maximum limit of black peaks.
Blanking	A signal which prevents the video information from registering on the face of a cathode ray tube. As a moving scanning-beam of a picture tube moves from the end of one line of picture information to the beginning of the next (or makes a longer move to the upper left corner of an entirely new picture field of video information), it must not make visible signal marks on the face of the tube. In effect the scanning beam must be blacked out during these moves. The signal controlling this black out is called the blanking signal. The length of time of the blackout is called the “blanking period” or “blanking interval”.
Blanking Level	In a composite video signal, blanking level corresponds with zero signal level. Below this level, in what might be termed the blacker-than-black or negative direction, are the sync pulses. Above this level, in the positive direction, the picture signals appear.
BNC	A type of connector commonly used in the television industry for interconnection of video signals.
Buffer	An information holding area in a computer, for temporary storage of data.
Burn In	To superimpose: for example, to burn in a title means to super a title (usually white) over a scene. See also KEY.
Byte	A unit of eight bits.
Cathode Ray Tube	In video, an electron tube designed to emit electrons (cathode ray) from a cathode at one end and to project them onto a light emitting fluorescent surface at the other end.
Character Generator	Electronic device used to create alpha numeric characters in video form.
Character Inserter	See Character Generator.
Character	Letters, numbers and punctuation marks.

Check Character	See CRC.
Clean Edit	An edit containing no electronic noise, distortion or other disruptions at the edit point.
Clipping	Any action that cuts off the peaks of the television signal. This may affect the positive (white) or negative (black) picture-signal peaks or synchronous signal peaks.
CMOS	Complimentary Metal Oxide Semiconductor. A very low power logic family.
Code	A system of rules and conventions according to which data can be formed, transmitted, received and processed.
Color Bar Signal	A test signal that provides the reference characteristics by which color equipment is adjusted. Also called "color bars" or "bars".
Color Black	A composite video signal containing sync, burst and set up signals (without distortion or video information) and constituting a black picture on the screen.
Color Burst	In NTSC color this refers to a burst of approximately 9 cycles of 3.6 MHz subcarrier on the back porch of the composite video signal. This is a color synchronizing signal to establish a frequency and phase reference for the chrominance signal.
Color Framing	A method of numbering frames in the NTSC and EBU color systems that identifies the sync to color subcarrier phase relationship. If this relationship is not preserved over an edit point, a horizontal picture shift may occur. This is not normally noticeable unless parts of the picture do not change on either side of the edit.
Component Video	A non-composite system in which a color picture is composed of three video signals; typically red, green and blue, or derivatives thereof.
Continuous Jam	Sets the generator time from an external source of time code at every frame. If an error occurs in the external time code, the generator generates the next frame expected in order to cover any errors. This means that time code may be copied with errors corrected by a Telcom Research time code generator with the continuous jam feature.

Control Track	The recorded track of a videotape that contains sync information. It consists of clean, constant electronic reference pulses recorded on the tape. The control track is used by the VTR for proper synchronization of the video head drum and capstan during playback of the video signal.
Crash Edit	An assemble edit made by manually forcing the VTR into record. It is not frame accurate and may not be repeated at the same point on the tape.
CRC	Cyclic redundancy check character. A method of detecting errors in serial data transmissions using polynomial manipulation and modulo arithmetic. During transmission the data stream (message polynomial) is divided by a selected polynomial. The remainder of this division (the check bits) is appended to the message. During receipt the both message and check bits are divided by the same polynomial. If there are no detectable errors the remainder of this division is zero. This is used in VITC error detection with a polynomial of X^8+1 .
CRT	See Cathode Ray Tube.
Cuts Only Editing	A basic mode of editing using only cuts (i.e. no special dissolves) to progress from scene to scene.
Cyclic Redundancy	See CRC.
Decoding Delay	A delay in the time code caused by the fact that a time code frame occurs simultaneously with its associated video frame. This means that by the time the code has been recovered and decoded the video frame is almost over. This is especially important in time code character inserters and jam sync generators. Usually the time code information is required at the start of the frame so all Telcom Research products correct for this delay.
Digital	An encoding method which uses binary numbers to represent data, such as video, audio or other signal information.
Digitize	To convert information into representative numbers. To convert analog information into digital information.
Double System	A production method in which the synchronous sound and picture are recorded as two separate elements.

Drop Frame	Drop Frame time code is an SMPTE operating standard that eliminates two frames at the beginning of each minute except for minutes 0, 10, 20, 30, 40, and 50. Drop Frame allows time code to run at almost exactly the same speed as a clock (real time) when used with NTSC color video.
Dropout	Loss of the picture, audio or time code signals, during tape play back. Usually caused by scratches or contamination on the tape or the oxide flaking off and leaving spots where no signal remains.
Dub	A copy of a tape. See also, “Master” and “Window Dub”.
Dubbing	This word has two meanings. (1) Erasing an audio track and recording new words, music or sound effects in its place. (2) Making copies of a tape, i.e. duplication.
Duplication Master	The tape from which copies (dubs) are made by the duplication house. Film-to-tape transfer masters and edited masters can serve as duplication masters, or a special “duplication master” can be made for dubbing, in which case it is second generation to either the film to tape transfer master or the edited master.
E.I.A.	Electronic Industries Association. An organization which sets standards and recommended practices in the electronics industry.
EBU	European Broadcast Union. Organization which defines standards used for color television in Europe.
Edit (Assemble)	See Assemble Editing.
Edit (Crash)	See Crash Edit.
Edit (Rough)	See Rough Edit.
Edit	Any point on a videotape where either the audio or the video content has been added to, deleted, replaced, extended, shortened or otherwise changed from its original form.

Edit Decision List	A permanent record (in the form of punched paper tape, floppy disk or printed copy) of all the edit decisions made for a video production. It contains information such as in-points, outpoints and effects; and is used for later automatic assembly of the selected portions of the original tapes into the final production or program.
Edit Log	Same as “Edit Decision List”.
Edit Source	Any Device that provides signals to be recorded in an edit session. Included are VTRs, ATRs, cameras, character generators, film chain, etc.
Edit Split	An edit in which the audio and video edit points are selected independently from each other. New audio can begin wither before or after the new video material is recorded.
Edited Master	The first generation of the fully edited videotape, the final program. Includes all video, all audio and all signals. The edited master incorporates images that are actually removed two or more generations form the master. Also called “edit master”.
Editing (Cuts Only)	See Cuts-Only Editing.
Editing (Electronic)	See Electronic Editing.
Editing (Off-line)	See Off-line Editing.
Editing (On-line)	See On-line Editing.
Editing (Time Code)	See Time Code Editing.
Editing	The process of executing a series of edits to reach the final form of a production or program. Not a physical assembly process, as in film editing, but a selective electronic transfer (dubbing) of video and/or audio sequences onto a new master videotape.
Editor	A person who edits.
EDL	See Edit Decision List
EDL	See Edit Decision List.

EFP	Abbreviation for Electronic Field Production. Sometimes used interchangeably with the term ENG.
EIA	Abbreviation for Electronics Industry Association. EIA is an U.S.-based trade association (principally for electronics manufacturers) with great influence on radio, television, and audio technical standards.
Electronic Editing	Electronically controlled assembling of selections of different video and/or audio sequences to produce finished programming. Electronic editing is not a physical editing assembly process, as is the splicing of film. It is, however, selective retransfer (duping) of video and/or audio onto a new master tape. Electronic editing is a postproduction procedure.
Endpoint	Where an edit ends. Also called “outpoint”.
ENG	Abbreviation for “electronic news gathering”. The business, techniques, and technology of new broadcasting audiovisuals using electronic cameras and videotape recorder/playback equipment instead of film equipment.
Field	(1) One-half (every other line) of a single TV frame. Two interlaced fields make one TV picture frame. Each field in the NTSC color TV video system has 262 1/2 lines of video information, and a complete frame has 525 lines.
Field Dominance	In video disk mastering, the order of the video fields established on the videotape during the editing or film to tape transfer process. A tape may possess either field one or field two dominance, the number referring to the video field on which each new picture begins. Throughout any videodisc master it is essential to maintain a constant field dominance or flickering will result. See also “Flicker”.
Film to Tape Transfer	The process of transferring optical picture images recorded on film to electronic picture images recorded on video tape.
Flicker	The undesirable visual alteration of two unmatched pictures commonly seen in freeze frame video. Flicker is caused by a field dominance change within a given frame creating a 1/60 of a second alteration of nonidentical fields.

Flutter	Rapid, undesired fluctuations in the pitch of reproduced sounds. If rate of fluctuation is less than 5Hz, the term “wow” is used.
Font	A complete alphabet (including numbers and punctuation marks) in a specific type style.
Frame	The total area occupied by a television picture, occurring in the NTSC system every 1/30 second and produced by a combination of two alternating fields.
Helical Scan	A videotape recorder/playback technology in which the video signal information is recorded diagonally on adjacent tracks. Sometimes called “Slant track”.
Hertz	A unit of frequency equal to one cycle per second. Cycles are referred to as Hertz in honor of Heinrich Hertz. Abbreviates Hz.
In-Point	On the record VTR, the place where the new material is to be recorded. On the source VTR, the beginning of the scene to be recorded.
Insert Edit	An edit in which new material is <i>inserted</i> into previously recorded material. The time code and control tracks are untouched. Only new audio or video or both are recorded. Normally a fully erased tape is recorded without audio and with black, time code and control track. Also see assemble editing.
Interlace	The scanning method whereby the first field of a video frame contains the odd scan lines. The marriage of the two fields or alternating interlace creates one full frame.
Invalid Time	Time code with frames greater than 29 (24 EBU) or seconds greater than 59 or minutes greater than 59 or hours greater than 23 or containing any digit above 9.
Iso Reels	Multiple reels of videotape recorded simultaneously on individual “isolated” VTRs from different cameras.
Jam Sync	Setting the generator time from an external source of time code such as a tape playback or another generator.

Key	A special effect accomplished by electronically “cutting a hole” in the video and inserting another picture or color in the area. The “hole” can be established in any size or shape by signals from a video camera, character generator or other video source.
kHz	One thousand Hertz. Abbreviated kHz. See Hertz, mHz.
Log	To keep a record. The record of events and/or decisions; such as edit logs and shooting logs.
Longitudinal	See LTC.
LTC	A form of time code recorded on a longitudinal track (audio or cue or address track) on an audio or video recorder. Also see VITC.
Manchester	See bi-phase.
Master	The original recording, the tape that comes directly from the videotape recorder. A master is first-generation recording.
Match Frame Edit	An invisible edit made by selecting an in-edit point that exactly matches a previously recorded frame. Usually used to extend the edit.
mHz	Megahertz, one million Hertz. Abbreviated mHz. See Hertz, kHz.
Microsecond	One millionth of a second, 10^{-6} second.
NAB	National Association of Broadcasters. An organization of the U.S. broadcasting industry, including networks, independents and cable system operators. Sets programming standards.
Nanosecond	One billionth of a second, 10^{-9} second.
Noise	Undesirable disturbances in a communications system. Noise can generate errors in transmission and reception. In audio, noise refers to extraneous sound interference.

NTSC	National Television Standards Committee, a broadcast engineering advisory group. NTSC also refers to the established 525-line, 60-field system for color television broadcasting that is standard in the North America and Japan.
Off-line Editing	A rough-cutting process using relatively inexpensive copies of original material, for purposes of establishing sources, continuity and timing of edit decisions.
On-line Editing	A term usually used to mean electronic editing and completion using equipment that produces the principal end results without intervening stages of either format or technology.
PAL-M	See PAL.
PAL	Phase Alternate Line, the 625-line, 50-field system used in the U.K., Western Europe, Scandinavia, Australia, South Africa and other regions. A complete sequence consists of eight fields, as opposed to four fields in NTSC. PAL-M is a the 525 line, 60 field variant of the PAL system used in Brazil.
Parallel	A method of data transfer in which all bits of information are transmitted simultaneously on separate wires.
Postproduction	All activities between the completion of the principle photography and the final approval of the production.
Preview	A rehearsal of an edit. Observing the results of a selected sequence of events without actually recording the signals on the record VTR. (1) BVB (Black-Video-Black) Preview: allows observation of the source VTR only so that the “fill” material can be viewed separately. The video monitor switches from black to source video and back to black during the preview. (2) VBV (Video-Black-Video) Preview: allows observation of the record VTR so that “information to remain unrecorded” may be viewed separately. The video monitor switches from record VTR to black/silence and back to record VTR, to help determine if material selected to remain on the tape is correct.

Protection Master	A duplicate of any of master tape, made in case its master is lost or damaged. Also called a “safety copy”. See also “Dub” and “Generation”.
Real Time	Actual time.
Rough Edit	A preliminary, rapid assembly of the different sequences of a program or production in the order of their appearance. It provides an approximate idea of the final program but is neither an edit master nor a clean edit list.
Scan Line	One single horizontal line of a TV picture.
Scene Log	A record of scenes and their order, usually including tape time, air time, time code address and comments regarding quality, content and how they relate to the script. See also “Log”.
Search	To program a tape-time location (by means of control track or SMPTE/EBU time code) and have the VTR go to that specific point on the tape.
SECAM	Sequential couleur a memoire (sequential color with memory) the French color television system also used within the Soviet Union and many satellite countries. The basis of operation is the sequential recording of primary colors in alternate lines.
Serial	A method of transmission in which each bit of information is sent sequentially on a single line rather than simultaneously as in parallel transmission.
Signal-to-Noise	The ratio of extraneous picture information (noise) to good video picture information signal inherent in video equipment or in a piece of videotape stock. S/N is usually expressed in decibels (dB). The higher the S/N ratio, the less grain (noise) and therefore the better picture.
SMPTE	Society of Motion Picture and Television Engineers. The organization which defines the the standards used for SMPTE time code.

SMPTE Time Code	A standardized format for longitudinal time code established by the SMPTE for use in the USA. It consists of an eight-digit number specifying hours, minutes, seconds and frames (to identify each frame on a tape)—plus eight sets of user bits (four bits each) for each frame, and 16 bits for synchronization of the time code reader. See also “Drop Frame Time Code” and “Time Code”.
Sync Generator	A signal generator used in a facility to synchronize all equipment, including edit controller. VTRs, etc.
Sync	The part of a television signal containing timing information used to control the scanning circuitry in a receiver or monitor.
Synchronous	In data communications, transmission in which the data bits are transmitted at a fixed rate with the transmitter and receiver synchronized. This eliminates the need for start/stop bits thus providing greater efficiency. Time code is a form of synchronous data transmission. See also ASYNCHRONOUS.
TCG	See Time Code Generator.
TCR	See Time Code Reader.
Three-Two Pull-down	(3:2) A technique for compensating for the differential between the film frame of 24 fps and that of video, 30 fps, during film to tape transfer. The first film frame is recorded on three video fields and the following frame on two fields resulting in a five field sequence.
Time-Base Corrector	An electronic unit for improving the stability of video signals by correcting the timing flaws inherent in videotape playbacks.
Time-Base Error	An error in the playback video from a VTR that results in slight timing variations and appears as visual “jitter” in the signal.
Time Code	An indexing address code using electronically generated numbers indexed as hours, minutes, seconds and frames as its reference. See also “SMPTE Time Code” and “Drop Frame Time Code”.

Time Code Editing	Using time code addressing and indexing during editing. This saves time and permits many functions, particularly searches for specific edit points, to be performed automatically.
Time Code Generator	A device for generating time code to be recorded on an audio or time code track in a VTR.
Time Code Reader	A device for reading the time code from an audio or time code track in a VTR, and translating the code into signals which can be used by an edit controller or read by the operator on a status display screen.
Trim	(1) To alter an edit point by the addition or subtraction of frames or time code value (hours, minutes, seconds, frames). (2) The sections of audiovisual material left over from the edit, i.e. a) head trim is the unused section prior to that which has been edited in, and b) tail trim is the unused section after that which has been edited in.
TTL	Transistor, transistor logic. A medium power, fast logic family.
USART	Universal Synchronous Asynchronous Receiver Transmitter. An integrated circuit which implements the logic to create either a synchronous or asynchronous data link. It converts bytes of data to serial form.
User Bits	32 bits or 4 bytes reserved in the time code for custom information. There is no preconceived format for this information and the bits may be interpreted in any way. Most Telcom Research time code readers and generators display these 32 bits in hexadecimal notation as 8 digits.
Valid Time	A time which exists in the 24 hour clock system. 13:24:56:12 is a valid time but 13:64:56:12 is not because 64 is not a valid number for minutes.
Vertical Blanking	Lines 1-21 of video field one and lines 263-284 of video field two, reserved for insertion of frame numbers, picture stops, chapter stops or other flags, captions or user defined information. These lines are not visually displayed on the screen.
VITC	A form of time code recorded in the television signal's vertical interval on two nonadjacent scan lines. The two lines contain the same information. This is done to improve reliability. Also see LTC.

Window Dubs	Duplicates of master tapes with time code usually displayed in a window in the picture. Used for off-line scene logging without a time code reader.
Word	A unit of 16 bits or 2 bytes.
Wow	Slow, undesired fluctuation in the pitch of reproduced sound. Wow is a form of flutter in which the rate of fluctuation is less than 5Hz.
XLR	A type of multiple pin connector commonly used in the television and sound industries. The three pin version is used for interconnection of audio signals and the four pin version is used for connecting battery power to portable equipment.
Z80	An eight bit microprocessor designed and manufactured by Zilog.

Parts List

B.1 Resistors

ITEM	DESCRIPTION	PART NUMBER	MANUFACTURER
R-1	4.7 K	CR25TOL05	PHILIPS
R-2	330 Ohms	CR25TOL05	PHILIPS
R-3	1 K Ohms	CR25TOL05	PHILIPS
R-4	1 K Ohms	CR25TOL05	PHILIPS
R-5	100 K Ohms	CR25TOL05	PHILIPS
R-6		not used	
R-7		not used	
R-8	27 Ohms	CR25TOL05	PHILIPS
R-9	27 Ohms	CR25TOL05	PHILIPS
R-10	27 Ohms	CR25TOL05	PHILIPS
R-11	27 Ohms	CR25TOL05	PHILIPS
R-12	27 Ohms	CR25TOL05	PHILIPS
R-13	27 Ohms	CR25TOL05	PHILIPS
R-14	27 Ohms	CR25TOL05	PHILIPS
R-15	220 Ohms	CR25TOL05	PHILIPS
R-16	220 Ohms	CR25TOL05	PHILIPS
R-17	220 Ohms	CR25TOL05	PHILIPS
R-18	220 Ohms	CR25TOL05	PHILIPS
R-19	220 Ohms	CR25TOL05	PHILIPS
R-20	220 Ohms	CR25TOL05	PHILIPS
R-21	220 Ohms	CR25TOL05	PHILIPS
R-22	220 Ohms	CR25TOL05	PHILIPS
R-23	4.7 K Ohms	CR25TOL05	PHILIPS
R-24	4.7 K Ohms	CR25TOL05	PHILIPS
R-25	4.7 K Ohms	CR25TOL05	PHILIPS
R-26	4.7 K Ohms	CR25TOL05	PHILIPS
R-27	4.7 K Ohms	CR25TOL05	PHILIPS
R-28	4.7 K Ohms	CR25TOL05	PHILIPS
R-29	4.7 K Ohms	CR25TOL05	PHILIPS
R-30	4.7 K Ohms	CR25TOL05	PHILIPS

R-31	1 K Ohms	CR25TOL05	PHILIPS
R-32	1 K Ohms	CR25TOL05	PHILIPS
R-33	1 K Ohms	CR25TOL05	PHILIPS
R-34	1 K Ohms	CR25TOL05	PHILIPS
R-35	1 K Ohms	CR25TOL05	PHILIPS
R-36	1 K Ohms	CR25TOL05	PHILIPS
R-37	1 K Ohms	CR25TOL05	PHILIPS
R-38	1 K Ohms	CR25TOL05	PHILIPS
R-39	10 K Ohms	CR25TOL05	PHILIPS
R-40		not used	
R-41		not used	
R-42		not used	
R-43		not used	
R-44		not used	
R-45		not used	
R-46		not used	
R-47	100 K Ohms	CR25TOL05	PHILIPS
R-48	100 K Ohms	CR25TOL05	PHILIPS
R-49	10 K Ohms	CR25TOL05	PHILIPS
R-50	1 K Ohms	CR25TOL05	PHILIPS
R-51	100 K Ohms	CR25TOL05	PHILIPS
R-52	100 K Ohms	CR25TOL05	PHILIPS
R-53	10 K Ohms	CR25TOL05	PHILIPS
R-54	18 K Ohms	CR25TOL05	PHILIPS
R-55	18 K Ohms	CR25TOL05	PHILIPS
R-56	Selected on test	CR25TOL05	PHILIPS
R-57	4.7 K Ohms	CR25TOL05	PHILIPS
R-58	Selected on test	CR25TOL05	PHILIPS
R-59	18 Ohms	CR25TOL05	PHILIPS
R-60	4.7 K Ohms	CR25TOL05	PHILIPS
R-61	1 K Ohms	CR25TOL05	PHILIPS
R-62	4.7 K Ohms	CR25TOL05	PHILIPS
R-63	5.1 K Ohms	CR25TOL05	PHILIPS
R-64	220 Ohms	CR25TOL05	PHILIPS
R-65	47 K Ohms	CR25TOL05	PHILIPS
R-66	100 Ohms	CR25TOL05	PHILIPS
R-67	330 Ohms	CR25TOL05	PHILIPS
R-68	4.7 K Ohms	CR25TOL05	PHILIPS
R-69	Selected on test	CR25TOL05	PHILIPS
R-70	2.2 K Ohms	CR25TOL05	PHILIPS
R-71	68 Ohms	CR25TOL05	PHILIPS
R-72	68 Ohms	CR25TOL05	PHILIPS
R-73	68 Ohms	CR25TOL05	PHILIPS
R-74	1 K Ohms	CR25TOL05	PHILIPS
R-75	2.2 K Ohms	CR25TOL05	PHILIPS
R-76	2.2 K Ohms	CR25TOL05	PHILIPS

R-77	10 K Ohms	CR25TOL05	PHILIPS
R-78	270 Ohms	CR25TOL05	PHILIPS
R-79	10 K Ohms	CR25TOL05	PHILIPS
R-80	4.7 K Ohms	CR25TOL05	PHILIPS
R-81	22 Ohms	CR25TOL05	PHILIPS
R-82	1 Meg.	CR25TOL05	PHILIPS
R-83	1 K Ohms	CR25TOL05	PHILIPS
R-84	1 K Ohms	CR25TOL05	PHILIPS
R-85	1 K Ohms	CR25TOL05	PHILIPS
R-86	1 K Ohms	CR25TOL05	PHILIPS
R-87	820 Ohms	CR25TOL05	PHILIPS
R-88	20 K Ohms	CR25TOL05	PHILIPS
R-89	130 K Ohms	CR25TOL05	PHILIPS
R-90	10 K Ohms	CR25TOL05	PHILIPS
R-91	1.8 K Ohms	CR25TOL05	PHILIPS
R-92		not used	
R-93		not used	
R-94	200 K Ohms	CR25TOL05	PHILIPS
R-101	10 K Ohms	CR25TOL05	PHILIPS
R-102	560 Ohms	CR25TOL05	PHILIPS
R-103	10 K Ohms	CR25TOL05	PHILIPS
R-104	560 Ohms	CR25TOL05	PHILIPS
R-105	10 K Ohms	CR25TOL05	PHILIPS
R-106	10 K Ohms	CR25TOL05	PHILIPS
R-107	560 Ohms	CR25TOL05	PHILIPS
R-108	560 Ohms	CR25TOL05	PHILIPS
R-109	68 Ohms	CR25TOL05	PHILIPS
R-110	68 Ohms	CR25TOL05	PHILIPS
R-111	10 K Ohms	CR25TOL05	PHILIPS
R-301		not used	
R-302		not used	
R-303	100 Ohms	CR25TOL05	PHILIPS
R-304	10 K Ohms	CR25TOL05	PHILIPS
R-305	18 K Ohms	CR25TOL05	PHILIPS
R-306	18 K Ohms	CR25TOL05	PHILIPS
R-307	56 K Ohms	CR25TOL05	PHILIPS
R-308	10 K Ohms	CR25TOL05	PHILIPS
R-309	47 K Ohms	CR25TOL05	PHILIPS
R-310	47 K Ohms	CR25TOL05	PHILIPS
R-311	130 K Ohms	CR25TOL05	PHILIPS
R-312	220 K Ohms	CR25TOL05	PHILIPS
R-313	1 Meg.	CR25TOL05	PHILIPS
R-314	39 K Ohms	CR25TOL05	PHILIPS
R-315	330 K Ohms	CR25TOL05	PHILIPS
R-316	680 K Ohms	CR25TOL05	PHILIPS
R-317	100 K Ohms	CR25TOL05	PHILIPS

R-318	100 K Ohms	CR25TOL05	PHILIPS
R-319	4.7 K Ohms	CR25TOL05	PHILIPS
R-320	15 K Ohms	CR25TOL05	PHILIPS
R-321	15 K Ohms	CR25TOL05	PHILIPS
R-322	180 Ohms	CR25TOL05	PHILIPS
R-323	10 K Ohms	CR25TOL05	PHILIPS
R-324	180 Ohms	CR25TOL05	PHILIPS
R-325	10 K Ohms	CR25TOL05	PHILIPS
R-326	180 Ohms	CR25TOL05	PHILIPS
R-327	10 K Ohms	CR25TOL05	PHILIPS
R-328	180 Ohms	CR25TOL05	PHILIPS
R-329	10 K Ohms	CR25TOL05	PHILIPS
R-330	470 K Ohms	CR25TOL05	PHILIPS
R-331	10 K Ohms	CR25TOL05	PHILIPS
R-332	47 K Ohms	CR25TOL05	PHILIPS
R-333	4.7 K Ohms	CR25TOL05	PHILIPS
R-334	4.7 K Ohms	CR25TOL05	PHILIPS
R-335	1 Meg	CR25TOL05	PHILIPS
R-336	4.7 K Ohms	CR25TOL05	PHILIPS
R-337	4.7 K Ohms	CR25TOL05	PHILIPS
R-338	330 Ohms	CR25TOL05	PHILIPS
R-339	330 Ohms	CR25TOL05	PHILIPS

B.2 Variable Resistors

ITEM	DESCRIPTION	PART NUMBER	MANUFACTURER
RV-1	1 Meg.	3386	Bourns
RV-2	1 Meg.	3386	Bourns
RV-3	2 K Ohms	3386	Bourns
RV-4	2 K Ohms	3386	Bourns
RV-5	1 Meg.	3386	Bourns
RV-101	100 K Ohms	388 N 100K	Clarostat
RV-102	100 K Ohms	388 N 100K	Clarostat

B.3 Capacitors

ITEM	DESCRIPTION	PART NUMBER	MANUFACTURER
C-1	.1 MFD 12 V CERAMIC	405484	STETTNER
C-2	.1 MFD 12 V CERAMIC	405484	STETTNER
C-3	1000 PF CERAMIC	CK05BX102K	AVX
C-4	10 MFD 16V TANTALUM	TAP 10M 16	I.T.T
C-5	.1 MFD 12 V CERAMIC	405484	STETTNER
C-6	.1 MFD 12 V CERAMIC	405484	STETTNER
C-7	3.3 MFD 20V TANTALUM	TAP 3.3M 20	I.T.T

C-8	.1 MFD 12 V CERAMIC	405484	STETTNER
C-9	.1 MFD 12 V CERAMIC	405484	STETTNER
C-10	.1 MFD 12 V CERAMIC	405484	STETTNER
C-11	.1 MFD 12 V CERAMIC	405484	STETTNER
C-12	.15 MFD METALLIZED FILM	344 21154	PHILIPS
C-13	10 MFD 16V TANTALUM	TAP 10M 16	I.T.T
C-14	330 PF CERAMIC	CK05BX331K	AVX
C-15	.1 MFD 12 V CERAMIC	405484	STETTNER
C-16	.1 MFD 12 V CERAMIC	405484	STETTNER
C-17	330 PF CERAMIC	CK05BX331K	AVX
C-18	1000 PF CERAMIC	CK05BX102K	AVX
C-19	.1 MFD 12 V CERAMIC	405484	STETTNER
C-20	.1 MFD 12 V CERAMIC	405484	STETTNER
C-21	10 PF CERAMIC	CK05BX100K	AVX
C-22	10 PF CERAMIC	CK05BX100K	AVX
C-23	Select on test	CK05BX470K	AVX
C-24	100 PF CERAMIC	CK05BX101K	AVX
C-25	33 MFD 6V TANTALUM	TAP 10M 16	I.T.T
C-26	.1 MFD 12 V CERAMIC	405484	STETTNER
C-27	.1 MFD 12 V CERAMIC	405484	STETTNER
C-28	.1 MFD 12 V CERAMIC	405484	STETTNER
C-29	.1 MFD 12 V CERAMIC	405484	STETTNER
C-30	.1 MFD 12 V CERAMIC	405484	STETTNER
C-31	100 PF CERAMIC	CK05BX101K	AVX
C-32		not used	
C-33	.1 MFD 12 V CERAMIC	405484	STETTNER
C-34	4.7 MFD 16V TANTALUM	TAP 4.7M 16	I.T.T
C-35	4.7 MFD 16V TANTALUM	TAP 4.7M 16	I.T.T
C-36	2.2 MFD 20 V TANTALUM	TAP 2.2M 20	I.T.T
C-37	.1 MFD 12 V CERAMIC	405484	STETTNER
C-38	.1 MFD 12 V CERAMIC	405484	STETTNER
C-39	.1 MFD 12 V CERAMIC	405484	STETTNER
C-40	1 MFD 20V TANTALUM	TAP 1M 20	I.T.T
C-41	10 PF CERAMIC	CK05BX100K	AVX
C-42	1.5 MFD 35 V TANTALUM	TAP 1.5M 35	I.T.T
C-43	1.5 MFD 35 V TANTALUM	TAP 1.5M 35	I.T.T
C-44	220 PF CERAMIC	CK05BX221K	AVX
C-45	1000 PF CERAMIC	CK05BX102K	AVX
C-46	.1 MFD 12 V CERAMIC	405484	STETTNER
C-47	.1 MFD 12 V CERAMIC	405484	STETTNER
C-48		not used	
C-49	4700 PF CERAMIC	CK05BX472K	AVX
C-50	1.5 MFD 35 V TANTALUM	TAP 1.5M 35	I.T.T
C-51		not used	
C-52		not used	
C-53	.1 MFD 12 V CERAMIC	405484	STETTNER

C-54		not used	
C-55	470 MFD. 25 V	437ET F470	PHILIPS
C-56	470 MFD. 25 V	437ET F470	PHILIPS
C-57	470 MFD. 25 V	437ET F470	PHILIPS
C-58	470 MFD. 25 V	437ET F470	PHILIPS
C-59	10000 MFD 16 V	SM16T103	United Chemicon
C-60	330 PF CERAMIC	CK05BX331K	AVX
C-61	27 PF CERAMIC	CK05BX270K	AVX
C-62	27 PF CERAMIC	CK05BX270K	AVX
C-63	220 PF CERAMIC	CK05BX221K	AVX
C-301	.33 MFD 20V TANTALUM	TAP .33M 20	I.T.T
C-302	.1 MFD 12 V CERAMIC	405484	STETTNER
C-303	1000 PF CERAMIC	CK05BX102K	AVX
C-304	.22 MFD 20V TANTALUM	TAP .22M 20	I.T.T
C-305	1000 PF CERAMIC	CK05BX102K	AVX
C-306	1000 PF CERAMIC	CK05BX102K	AVX
C-307	1000 PF CERAMIC	CK05BX102K	AVX
C-308	.22 MFD 20V TANTALUM	TAP .22M 20	I.T.T
C-309	.33 MFD 20V TANTALUM	TAP .33M 20	I.T.T
C-310	1000 PF CERAMIC	CK05BX102K	AVX
C-311	.47 MFD 35 V TANTALUM	TAP .47M 35	I.T.T
C-312	.1 MFD 12 V CERAMIC	405484	STETTNER
C-313	1 MFD 35 V TANTALUM	TAP 1M 35	I.T.T
C-314	1000 PF CERAMIC	CK05BX102K	AVX
C-315	1000 PF CERAMIC	CK05BX102K	AVX
C-316	33 MFD 6V TANTALUM	TAP 33M 6	I.T.T
C-317	33 MFD 6V TANTALUM	TAP 33M 6	I.T.T
C-318	33 MFD 6V TANTALUM	TAP 33M 6	I.T.T
C-319	33 MFD 6V TANTALUM	TAP 33M 6	I.T.T
C-320	3.3 MFD 20V TANTALUM	TAP 3.3M 20	I.T.T
C-321	4700 PF CERAMIC	CK05BX472K	AVX
C-322	.1 MFD 12 V CERAMIC	405484	STETTNER
C-323	.1 MFD 12 V CERAMIC	405484	STETTNER
C-324	1800 PF CERAMIC	CK05BX182K	AVX

B.4 Integrated Circuits

ITEM	DESCRIPTION	PART NUMBER	MANUFACTURER
U-1	SCHOTTKY I.C.	SN74LS04N	TEXAS INST.
U-2	not used		
U-3	NMOS I.C.	Z80A-CPU	ZILOG
U-4	SCHOTTKY I.C.	SN74LS04N	TEXAS INST.
U-5	SCHOTTKY I.C.	SN74LS138N	TEXAS INST.
U-6	SCHOTTKY I.C.	SN74LS138N	TEXAS INST.
U-7	SCHOTTKY I.C.	SN74LS138N	TEXAS INST.

U-8	NMOS I.C.	2732A	INTEL
U-9	not used		
U-10	NMOS I.C.	2114A-4	INTEL
U-11	NMOS I.C.	2114A-4	INTEL
U-12	NMOS I.C.	P8251A	INTEL
U-14	NMOS I.C.	8279	INTEL
U-15	NMOS I.C.	8276	INTEL
U-16	NMOS I.C.	P8255A	INTEL
U-17	NMOS I.C.	P8255A	INTEL
U-18	CMOS I.C.	MC14538B	MOTOROLA
U-19	CMOS I.C.	MC14538B	MOTOROLA
U-20	SCHOTTKY I.C.	SN74LS107N	TEXAS INST.
U-21	SCHOTTKY I.C.	SN74LS20N	TEXAS INST.
U-22	SCHOTTKY I.C.	SN74LS02N	TEXAS INST.
U-23	CMOS I.C.	MC14049UB	MOTOROLA
U-24	SCHOTTKY I.C.	SN74LS166N	TEXAS INST.
U-25	SCHOTTKY I.C.	SN74LS166N	TEXAS INST.
U-26	SCHOTTKY I.C.	SN74LS174N	TEXAS INST.
U-27	SCHOTTKY I.C.	SN74LS86N	TEXAS INST.
U-28	SCHOTTKY I.C.	SN74LS10N	TEXAS INST.
U-29	SCHOTTKY I.C.	SN74LS163N	TEXAS INST.
U-30	NMOS I.C.	2732A	INTEL
U-31	NMOS I.C.	2732A	INTEL
U-32	SCHOTTKY I.C.	SN74LS95AN	TEXAS INST.
U-33	SCHOTTKY I.C.	SN74LS02N	TEXAS INST.
U-34	CMOS I.C.	74HC4066	MOTOROLA
U-36	not used		
U-37	CMOS I.C.	MC14046B	MOTOROLA
U-38	CMOS I.C.	MC14013B	MOTOROLA
U-39	CMOS I.C.	MC14070B	MOTOROLA
U-40	LINEAR I.C.	LM311N	NATIONAL
U-41	LINEAR I.C.	CA3046	R.C.A.
U-42	LINEAR I.C.	LM311N	NATIONAL
U-43	-5 VOLT REGULATOR	MC7905P	MOTOROLA
U-44	12 VOLT REGULATOR	MC7812P	MOTOROLA
U-45	+5 VOLT REGULATOR	MC7805P	MOTOROLA
U-46	CMOS I.C.	MC14538B	MOTOROLA
U-47	CMOS I.C.	74HC4066	MOTOROLA
U-101	SCHOTTKY I.C.	SN74LS138N	TEXAS INST.
U-301	LINEAR I.C.	LM311N	NATIONAL
U-302	CMOS I.C.	MC14538B	MOTOROLA
U-303	CMOS I.C.	MC14538B	MOTOROLA
U-304	CMOS I.C.	MC14538B	MOTOROLA
U-305	CMOS I.C.	MC14001	MOTOROLA
U-306	CMOS I.C.	MC14538B	MOTOROLA
U-307	CMOS I.C.	MC14046B	MOTOROLA

U-308	SCHOTTKY I.C.	SN47LS74AN	MOTOROLA
U-309	CMOS I.C.	MC14584B	MOTOROLA

B.5 Diodes

ITEM	DESCRIPTION	PART NUMBER	MANUFACTURER
D-1	GERMANIUM DIODE	1N270	
D-2	GERMANIUM DIODE	1N270	
D-3	SILICON DIODE	1N4148	PHILIPS
D-4	SILICON RECTIFIER	1N4001	PHILIPS
D-5	SILICON RECTIFIER	1N4001	PHILIPS
D-6	SILICON RECTIFIER	1N4001	GEN. INST.
D-7	SILICON RECTIFIER	1N4001	GEN. INST.
D-8	SILICON RECTIFIER	MR501	MOTOROLA
D-9	SILICON RECTIFIER	MR501	MOTOROLA
D-10	SILICON RECTIFIER	1N4001	GEN. INST.
D-11	SILICON RECTIFIER	1N4001	GEN. INST.
D-301	GERMANIUM DIODE	1N270	MOTOROLA
D-302	SILICON DIODE	1N4148	PHILIPS
L-101	L.E.D.	MV5753	GEN. INST.
L-102	L.E.D.	MV5753	GEN. INST.
L-103	L.E.D.	MV5753	GEN. INST.
L-104	L.E.D.	MV5753	GEN. INST.
L-105	L.E.D.	MV5753	GEN. INST.
L-106	L.E.D.	MV5753	GEN. INST.
L-108	L.E.D.	MV5753	GEN. INST.
L-109	L.E.D.	MV5753	GEN. INST.
L-110	L.E.D.	MV5753	GEN. INST.
L-111	L.E.D.	MV5753	GEN. INST.
L-112	L.E.D.	MV5753	GEN. INST.
L-113	L.E.D.	MV5753	GEN. INST.
L-201	L.E.D.	MV5753	GEN. INST.
L-202	L.E.D.	MV5753	GEN. INST.
L-203	L.E.D.	MV5753	GEN. INST.
L-204	L.E.D.	MV5753	GEN. INST.
L-205	L.E.D.	MV5753	GEN. INST.
L-206	L.E.D.	MV5753	GEN. INST.
DP-1	7 SEGMENT DISPLAY	MAN8610	GEN. INST.
DP-2	7 SEGMENT DISPLAY	MAN8610	GEN. INST.
DP-3	7 SEGMENT DISPLAY	MAN8610	GEN. INST.
DP-4	7 SEGMENT DISPLAY	MAN8610	GEN. INST.
DP-5	7 SEGMENT DISPLAY	MAN8610	GEN. INST.
DP-6	7 SEGMENT DISPLAY	MAN8610	GEN. INST.
DP-7	7 SEGMENT DISPLAY	MAN8610	GEN. INST.
DP-8	7 SEGMENT DISPLAY	MAN8610	GEN. INST.

B.6 Transistors

ITEM	DESCRIPTION	PART NUMBER	MANUFACTURER
Q-1	PNP SILICON	MPS6562	MOTOROLA
Q-2	PNP SILICON	MPS6562	MOTOROLA
Q-3	PNP SILICON	MPS6562	MOTOROLA
Q-4	PNP SILICON	MPS6562	MOTOROLA
Q-5	PNP SILICON	MPS6562	MOTOROLA
Q-6	PNP SILICON	MPS6562	MOTOROLA
Q-7	PNP SILICON	MPS6562	MOTOROLA
Q-8	PNP SILICON	MPS6562	MOTOROLA
Q-9	NPN SILICON	2N4401	MOTOROLA
Q-10	NPN SILICON	2N4401	MOTOROLA
Q-11	NPN SILICON	2N4401	MOTOROLA
Q-12	NPN SILICON	2N4401	MOTOROLA
Q-13	NPN SILICON	2N4401	MOTOROLA
Q-14	NPN SILICON	2N4401	MOTOROLA
Q-15	NPN SILICON	2N4401	MOTOROLA
Q-16	NPN SILICON	2N4401	MOTOROLA
Q-17	NPN SILICON	2N4401	MOTOROLA
Q-18	NPN SILICON	2N4401	MOTOROLA
Q-101	NPN SILICON	2N4401	MOTOROLA
Q-102	NPN SILICON	2N4401	MOTOROLA
Q-103	NPN SILICON	2N4401	MOTOROLA
Q-104	NPN SILICON	2N4401	MOTOROLA
Q-105	NPN SILICON	2N4401	MOTOROLA
Q-301	NPN SILICON	2N4401	MOTOROLA
Q-302	NPN SILICON	2N4401	MOTOROLA
Q-303	PNP SILICON	2N4403	MOTOROLA
Q-304	NPN SILICON	2N4401	MOTOROLA
Q-305	PNP SILICON	2N4403	MOTOROLA
Q-306	NPN SILICON	2N4401	MOTOROLA

B.7 Connectors

ITEM	DESCRIPTION	PART NUMBER	MANUFACTURER
P-1	20 PIN HEADER	IDH 20 NP	ROBINSON/NUGENT
P-2	20 PIN HEADER	IDH 20 NP	ROBINSON/NUGENT
P-3	34 PIN HEADER	IDH 34 NP	ROBINSON/NUGENT
P-4	14 PIN HEADER	87546-6	AMP
P-5	20 PIN HEADER	IDH 20 NP	ROBINSON/NUGENT
P-6	20 PIN HEADER	IDH 20 NP	ROBINSON/NUGENT
P-7	8 PIN HEADER	IDH 8 NP	ROBINSON/NUGENT
P-101	20 PIN HEADER	IDH 20 NP	ROBINSON/NUGENT
P-102	20 PIN HEADER	IDH 20 NP	ROBINSON/NUGENT

P-201	20 PIN HEADER	IDH 20 NP	ROBINSON/NUGENT
J-1	BNC JACK	31-221	AMPHENOL
J-2	BNC JACK	31-221	AMPHENOL
J-3	BNC JACK	31-221	AMPHENOL
J-4	BNC JACK	31-221	AMPHENOL
J-5	BNC JACK	31-221	AMPHENOL
J-6	BNC JACK	31-221	AMPHENOL
J-7	4 PIN CONNECTOR	GH4F-SCLRN	POSITRONICS
J-8	LOCKING CONNECTOR	C3F	SWITCHCRAFT
J-9	4 PIN PLUG	GH4M-SCLSH110	POSITRONICS

B.8 Switches

ITEM	DESCRIPTION	PART NUMBER	MANUFACTURER
SW-1	N.O. PUSH-BUTTON	87CC3 201	GRAYHILL
SW-2	N.O. PUSH-BUTTON	87CC3 201	GRAYHILL
SW-3	N.O. PUSH-BUTTON	87CC3 201	GRAYHILL
SW-4	N.O. PUSH-BUTTON	87CC3 201	GRAYHILL
SW-5	N.O. PUSH-BUTTON	87CC3 201	GRAYHILL
SW-6	N.O. PUSH-BUTTON	87CC3 201	GRAYHILL
SW-7	N.O. PUSH-BUTTON	87CC3 201	GRAYHILL
SW-8	N.O. PUSH-BUTTON ARRAY	87FC3 201	GRAYHILL
SW-9	N.O. PUSH-BUTTON ARRAY	87FC3 201	GRAYHILL
SW-10	N.O. PUSH-BUTTON ARRAY	87FC3 201	GRAYHILL
SW-11	N.O. PUSH-BUTTON ARRAY	87FC3 201	GRAYHILL
SW-12	N.O. PUSH-BUTTON ARRAY	87FC3 201	GRAYHILL
SW-13	N.O. PUSH-BUTTON	87CC3 201	GRAYHILL
SW-14	N.O. PUSH-BUTTON	87CC3 201	GRAYHILL
SW-15	N.O. PUSH-BUTTON	87CC3 201	GRAYHILL
SW-16	N.O. PUSH-BUTTON	87CC3 201	GRAYHILL

B.9 Miscellaneous

ITEM	DESCRIPTION	PART NUMBER	MANUFACTURER
JP-1	JUMPER PLUG	530153-2	AMP
JP-2	JUMPER PLUG	530153-2	AMP
JP-3	JUMPER PLUG	530153-2	AMP
JP-4	JUMPER PLUG	530153-2	AMP
T-1	16V. 1 Amp. TRANSFORMER	DPC 16-1500	SIGNAL
BR-1	TRANSFORMER BRACKET	24-BR	SIGNAL
XTAL	4.0 MHZ	CTS4000	CTS
SO-1	24 PIN I.C. SOCKET	640361-1	AMP
SO-2		not used	
SO-3	24 PIN I.C. SOCKET	640361-1	AMP

SO-4	24 PIN I.C. SOCKET	640361-1	AMP
PWR-1	POWER SELECTOR/ FUSE HOLDER	06A5	DELTA
F-1	FUSE	218.250	LITTLEFUSE
CA-1	FLAT CABLE ASSEMBLY	TC5010-01	TELCOM
CA-2	FLAT CABLE ASSEMBLY	TC5010-01	TELCOM
CA-3	FLAT CABLE ASSEMBLY	TC5010-02	TELCOM
CA-4	FLAT CABLE ASSEMBLY	TC5010-03	TELCOM
CA-5	FLAT CABLE ASSEMBLY	TC5010-01	TELCOM
PCB-1	MAIN CIRCUIT BOARD	5010M REV 2.7	TELCOM
PCB-2	DISPLAY CIRCUIT BOARD	5010D REV 0.1	TELCOM
PCB-3	CONTROL CIRCUIT BOARD	5010C REV 0.2	TELCOM
CS-1	ALUMINUM CHASSIS	D-II 3.5	TELCOM
RP-1	REAR PANEL	D-II RP	TELCOM
FP-1	FRONT PANEL	D-II FP	TELCOM
KN-1	KNOB	KNS501BA 1/8	ALCO
KN-2	KNOB	KNS501BA 1/8	ALCO
FPO-1	FRONT PANEL OVERLAY	73540FP	TELCOM

Schematics

Index

+ 18
- 18
24 16
25 16
30 16
0-9 17

A

A-F 17
address track 2
ASCII 31
Assemble Editing 31
Asynchronous 31
Asynchronous time code 10, 15, 17
audio track 2
Auto Assembly 31
Auto Conforming 31

B

B.C.D. 31
Back Porch 31
Back Time 31
Bi-Phase Mark 2, 31
Bit 31
Black Level 32
Blanking 32
Blanking Level 32
BNC 10, 32
Border 18
Buffer 32
Burn In 32
Byte 32

C

C.C.I.R. Report 624-1 7, 11
Cathode Ray Tube 32
CE 18

CF 3
Character 32
Character Generator 32
Character Inserter 32
Check Character 32
Clean Edit 33
Clipping 33
CMOS 33
Code 33
Color Bar Signal 33
Color Black 33
Color Burst 33
Color frame 16
color frame flag 3
color frame identification pulse 6
Color Framing 33
Color framing 7, 12, 17
Component Video 33
Continuous Jam 33
Continuous jam 10, 16, 17, 25
Control conector 12
Control Track 33
Crash Edit 34
CRC 5, 34
CRT 34
cue track 2
Cuts Only Editing 34
Cyclic Redundancy 34
cyclic redundancy check character 5

D

Decoding Delay 34
DF 16
Digital 34
Digitize 34
Display brightness 29
Double System 34
Drop Frame 3, 5, 34

Dropout 35
Dub 35
Dubbing 35
Duplication Master 35

E

E.I.A. 35
E.I.A. RS170 7, 11
EBU 2, 3, 4, 5, 6, 7, 31, 33, 35, 38, 41
Edit 35
Edit (Assemble) 35
Edit (Crash) 35
Edit (Rough) 35
Edit Decision List 35
Edit Log 36
Edit Source 36
Edit Split 36
Edited Master 36
Editing 36
Editing (Cuts Only) 36
Editing (Electronic) 36
Editing (Off-line) 36
Editing (On-line) 36
Editing (Time Code) 36
Editor 36
EDL 36
EFP 36
EIA 37
Electronic Editing 37
Endpoint 37
ENG 37
Enter 18
Environmental 8
Error 15, 16, 24, 25, 30
error detection 34
Error indicator 12
External hold 12
External jam 7, 12

F

Field 37
Field Dominance 37
Film to Tape Transfer 37
Flicker 37
Flutter 37

Font 38
Frame 38
Framed 16
Frames 18

H

Helical Scan 38
Hertz 38
Hold 12, 16, 17, 30
Horizontal 18
Horizontal Position control 29
Horizontal Trim 29

I

In/Out 9
In-Point 38
Insert 18
Insert Edit 38
Interchanged tapes 10
Interlace 38
Invalid Time 38
Inverse 18
Iso Reels 38

J

Jam Sync 10, 12, 15, 23, 25, 38
Jam sync 16
Jam User bits 10
Jumper options 9

K

Key 38
kHz 39

L

L.E.D. brightness 29
L.E.D. display 15
Line 16
Line voltage 12
Lock 16
Log 39
Longitudinal 39
longitudinal time code 2
LTC 2, 39

M

Manchester 39
Master 39
Match Frame Edit 39
mHz 39
Microprocessor 23
Microsecond 39

N

NAB 39
Nanosecond 39
Noise 39
NTSC 3, 4, 5, 6, 33, 35, 37, 38, 39, 40

O

Off-line Editing 40
On-line Editing 40

P

PAL 40
PAL-M 40
Parallel 40
Parallel Input/Output 8, 9, 12
Parallel interface 9
phase-locked 3
Phase locked loop 16, 23, 24
Postproduction 40
Power 8
Preview 40
Protection Master 40

R

Reader time to user bits 17
Real Time 41
Reference sync 16
Reference sync 7, 11, 24
Remote control 12
Rough Edit 41

S

Scan Line 41
Scene Log 41
Search 41
SECAM 41
Serial 41

Signal-to-Noise 41
Size 8
SMPTE 2, 4, 5, 31, 35, 41
SMPTE Time Code 41
Standards 17
start of frame 3
SVHS 10
Sync 42
sync bits 5
Sync'd 15
Sync Generator 42
Sync input 11
sync word 3
Synchronous 42
Synchronous time code 10, 15, 17

T

TCG 42
TCR 42
Test 10
Three-Two Pull-down 42
Time 16, 17
Time-Base Corrector 42
Time-Base Error 42
time bits 2
Time Code 42
Time Code Editing 42
time code frame 3
Time Code Generator 43
Time code input 8, 11
Time code output 10
Time Code Reader 43
Time/User 9
timing relationship 3
Trim 43
TTL 43

U

U-matic 10
Unpacking 9
USART 43
User 16
User Bits 43
User bits 10, 12, 15, 17, 18
user bits 3
User bits from reader time 17

V

Valid Time 43

Vertical 18

Vertical Blanking 43

Vertical interval 12, 24

Vertical Position control 29

Vertical Trim 29

Video input 7, 11

Video output 11, 29

VITC 5, 34, 43

W

Weight 8

Window Dubs 43

Word 44

Wow 44

X

XLR 10, 44

Z

Z80 44

Z80A 23